

Half-pitch and Multi-function Two Piece Connector

FX2 Series

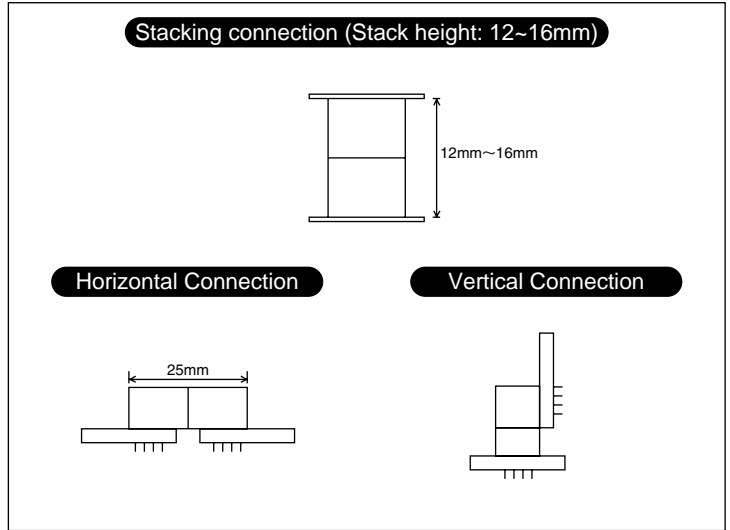
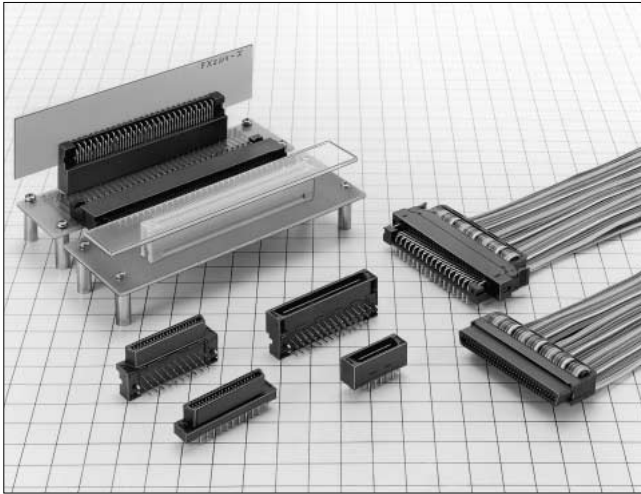

■ Features

1. Various connection with various product line

Stacking connection		Vertical type		Cable connection
DIP type	MT type	DIP type	SMT type	
↓				
		DIP type	SMT type	Cable only

DIP type 	⇔	Horizontal type
SMT type 		
		Vertical type
		DIP type
		SMT type
Cable only 		Cable connection

2. Easy One-Touch Operation

The ribbon cable connection type allows easy one-touch operation with either single hand.

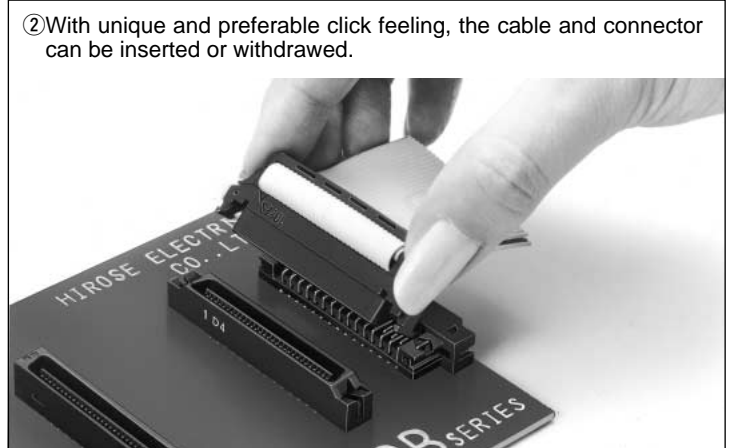

(For insertion, the operation proceeds from procedure (2) to (1).)

3. Board to board type

① Flux swell prevention

The straight dip type takes the complete flux tight action from the board back side at solder dipping. The type is prepared, corresponding to whether or not cleaning is required.

② Stack height 12mm to 16mm

The board stack height can be set to every 1 mm unit up to 12 to 16mm.

③ Mis-insertion preventive mechanism

The mating area is designed in a mechanism so as to prevent mis-insertion, and complete countermeasures have been taken against wrenching.

4. Board to cable type

① Complete lock with easy operation

Employing the inner lock system, complete lock and eject actions can be performed with easy operation.

② Applicable cable

The applicable cable is the <UL2651>AWG#28 flat cable (7/0.127mm), and the jacket size is 0.9±0.1mm.

5. SMT type

① Strength security with metaltab

The right angle type is equipped with metaltab to secure soldering strength, and constructed so as to fix by screws. The straight type can choose whether or not metaltab are required.

■Applications

Computers, peripheral equipments, various machines etc.

■Product Specifications

Rating	Current rating 0.5A	Operating Temperature Range -55°C to +85°C (Note 1)	Storage Temperature Range -10°C to +60°C (Note 2)
	Voltage rating 125V AC	Operating Humidity Range 40 to 80%	Storage Humidity Range 40 to 70% (Note 2)

Item	Specification	Condition
1. Insulation Resistance	1000M ohms min	250V DC
2. Withstanding Voltage	No flashover or insulation breakdown.	300V AC/1 minute
3. Contact Resistance	45m ohms max.	100mA
4. Vibration	No electrical discontinuity of 1μs or more	Frequency: 10 to 55 Hz, single amplitude of 0.75 mm, 2 hours in each of the 3 directions.
5. Humidity (Steady state)	Contact resistance: 55m ohms max. Insulation resistance: 100M ohms min.	96 hours at temperature of 40°C and humidity of 90% to 95%
6. Temperature Cycle	Contact resistance: 55m ohms max. Insulation resistance: 100M ohms min. No damage, cracks, or parts looseness.	(-55°C: 30 minutes → 15 to 35°C: 2 to 3 minutes → 85°C: 30 minutes → 15 to 35°C: 2 to 3 minutes) 5 cycles
7. Operation Life	Contact resistance: 55 m ohms max.	500 cycles
8. Resistance to soldering heat	No deformation of components affecting performance.	Reflow: At the recommended temperature profile Manual soldering: 260°C for 10 seconds

Note 1: Includes temperature rise caused by current flow.

Note 2: The term "storage" refers to products stored for long period of time prior to mounting and use. Operating Temperature Range and Humidity range covers non conducting condition of installed connectors in storage, shipment or during transportation.

■Material

Parts		Material	Finish	Remark
Insulator	Dip type	Polyamid	Black	UL94V-0
	Socket	PBT/Polyamid		
	SMT type	PPS	Light brown	
Contact	Receptacle	Phosphor bronze	Selective gold plating	_____
	Socket			
	Header	Phosphor bronze or brass		

■Stacking Variation

Unit:mm

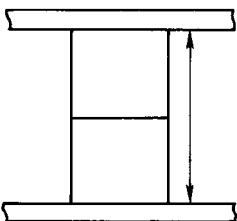

Header		Receptacle	Dip type		SMT type
			FX2C-*S-1.27DSA(L)	FX2C2-*S-1.27DSA(L)	FX2-*S-1.27SV(L)
Dip type	FX2C-*P-1.27DSA(L)	12	14.0	12.2	
	FX2CA-*P-1.27DSA(L)				
	FX2CA1-*P-1.27DSA(L)				
	FX2CA2-*P-1.27DSA(L)				
SMT type	FX2-*P-1.27SV(L)	12.1	14.1	12.3	

■ Ordering Information

● Board to Board Receptacle

FX2 CA 2 - * S - 1.27 DSA L
 ① ② ③ ④ ⑤ ⑥ ⑦ ⑧

① Series Name :FX2	④ Number of contacts: 20, 32, 40, 52, 60, 68, 80, 100, 120
② None : Right angle type C : Straight non-cleaning type CA : Straight cleaning type	⑤ Connector type: S: Receptacle
③ Product height variation (DSA only) None : Standard product 2 : +2mm	⑥ Contact pitch: 1.27mm
	⑦ Dip contact style DS : Right angle type DSA : Straight type
	⑧ L: Board prefixed pin

● Board to Board Header

FX2 CA 1 - * P - 1.27 DSA L
 ① ② ③ ④ ⑤ ⑥ ⑦ ⑧

① Series Name :FX2	④ Number of contacts: 20, 32, 40, 52, 60, 68, 80, 100, 120
② None : Right angle type C : Straight non-cleaning type CA : Straight cleaning type	⑤ Connector type: P: header
③ Product height variation (DSA only) None : Standard product 1 : +1mm 2 : +2mm	⑥ Contact pitch: 1.27mm
	⑦ Dip contact style: DS : Right angle type DSA : Straight type
	⑧ L: Board prefixed pin

Note 1. C and CA take complete countermeasures against flux.

Note 2. Cleaning type: the liquid escape hole is added at dip cleaning.

Note 3. No-cleaning type: no liquid escape hole is added at dip cleaning.

● Board to Cable Socket

FX2 BA - * S A - 1.27 R
 ① ② ③ ④ ⑤ ⑥ ⑦

① Series Name : FX2	④ S: Socket
② B : Lock cable type BA : No lock cable type	⑤ A: Contact material: phosphor bronze
③ Number of contacts: 20, 32, 40, 52, 60, 68, 80, 100	⑥ Contact pitch: 1.27mm
	⑦ R: Insulation displacement

●Board to Cable Header

FX2 BA - * P A - 1.27 DSA L
 ① ② ③ ④ ⑤ ⑥ ⑦ ⑧

① Series Name : FX2	⑤ None : Contact material: phosphor bronze A : Contact material: brass
② B : Lock straight no cleaning type : Lock right angle type BA : Lock straight cleaning type	⑥ Contact pitch: 1.27mm
③ Number of contacts: 20, 32, 40, 52, 60, 68, 80, 100	⑦ Dip Contact style: DS : Right angle type DSA : Straight type
④ Connector type: P: header	⑧ L: Board prefixed pin

Note 1. Cleaning type: The liquid escape hole is added at dip cleaning.
 Note 2. No cleaning type: No liquid escape hole is added at dip cleaning.
 Note 3. Straight 20 and 32 contact types use phosphor bronze for contact material.

●Straight SMT Type

FX2 - * P - 1.27 SV L
 ① ② ③ ④ ⑤ ⑥

① Series Name :FX2	④ Contact pitch: 1.27mm
② Number of contacts: 20, 32, 40, 52, 60, 68, 80, 100, 120	⑤ Contact style: SV: Straight SMT type
③ Connector type: P: Header S: Receptacle	⑥ L: Board prefixed pin

●Header Right Angle SMT Type

FX2 A - * P - 0.635 SH
 ① ② ③ ④ ⑤ ⑥

① Series Name :FX2	④ Connector type: P: Header
② None : With boss A : Without boss	⑤ Mounting area pitch: 0.635mm
③ Number of contacts: 20, 40, 52, 60, 80	⑥ Contact style SH: Right angle SMT type

◆FX2 Functional Flow Chart

Board to Board Cable Type

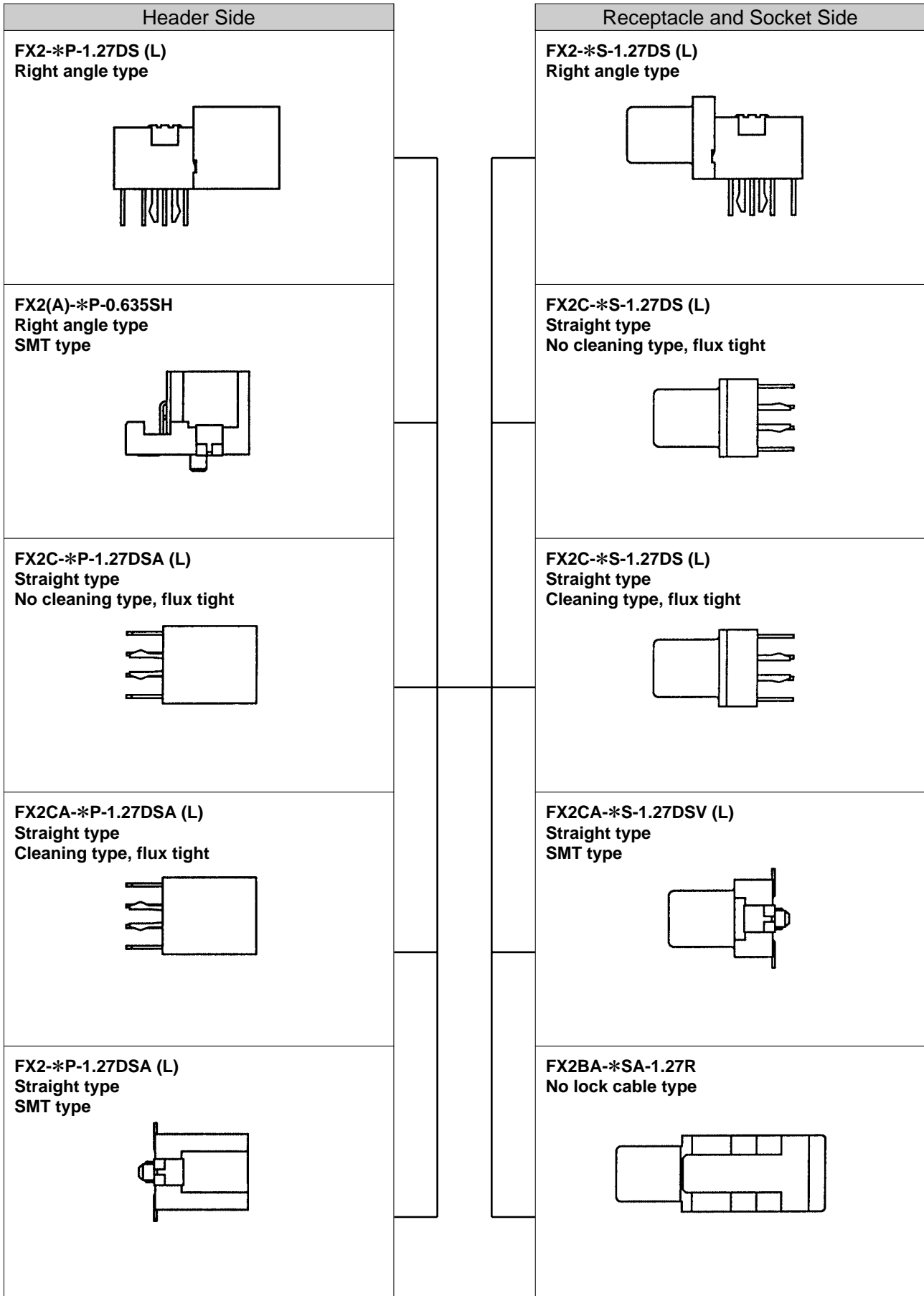

◆FX2 Functional Flow Chart

Board to Board Cable Type

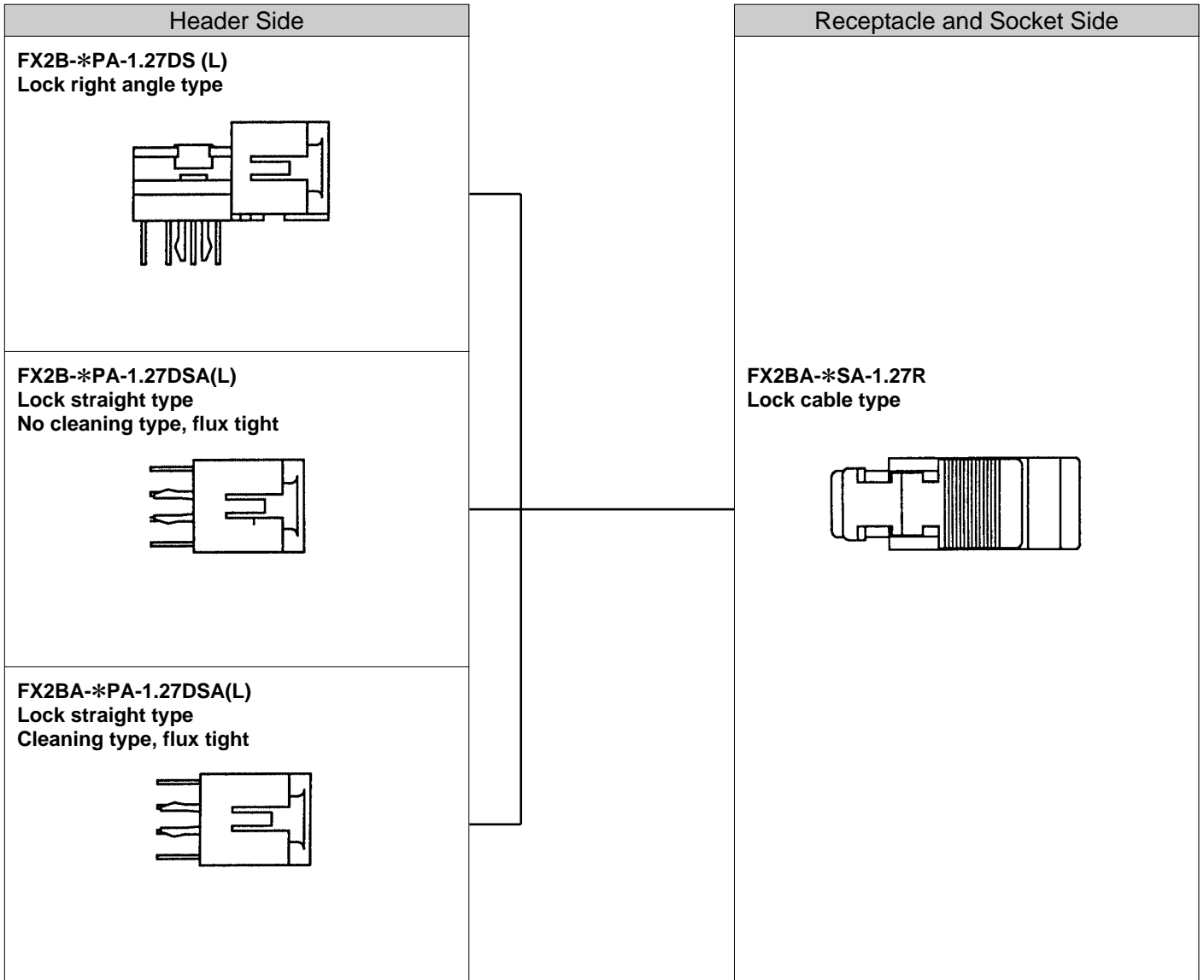

◆ Dip Type Application Pattern

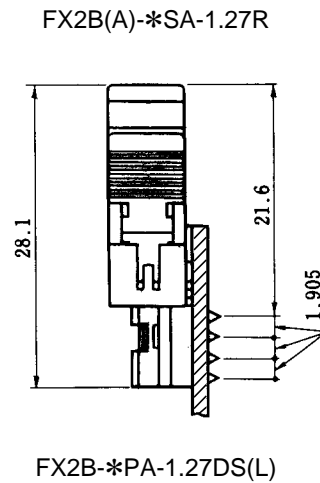
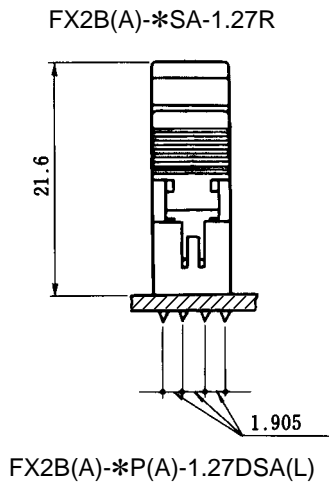
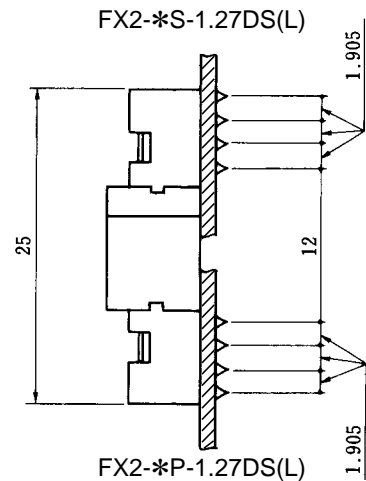
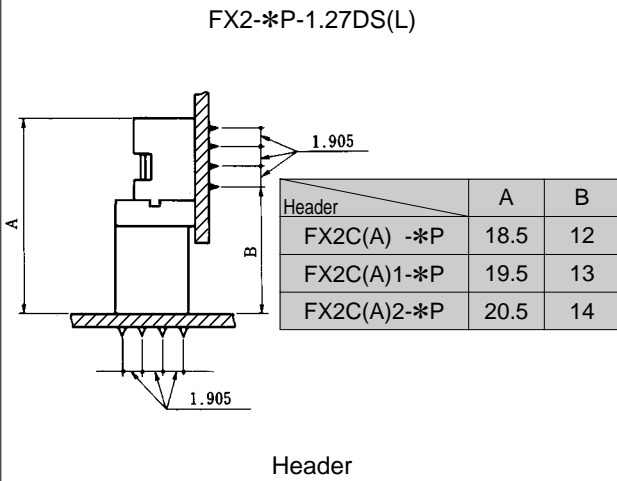
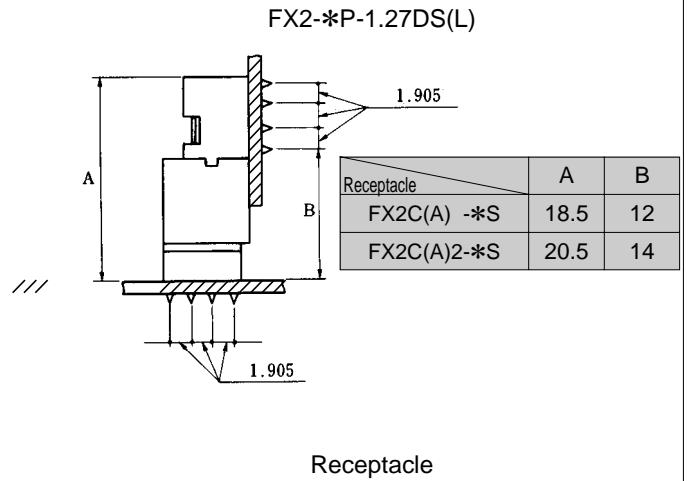
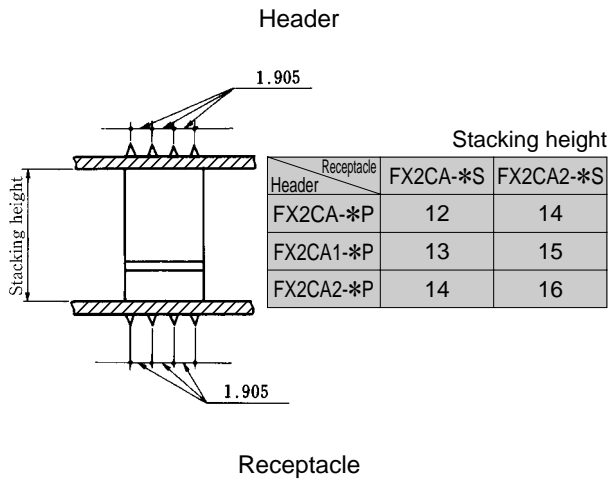

◆SMT Type Application Pattern

FX2-*P-1.27SV(L)

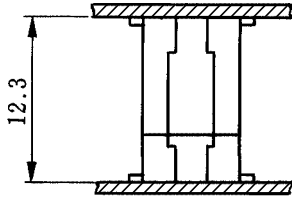

FX2-*S-1.27SV(L)

FX2-*P-1.27SV(L)

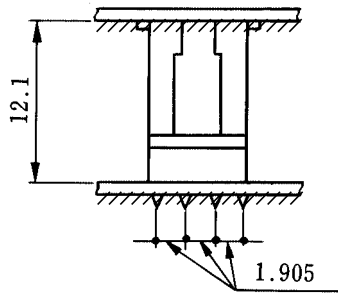

FX2C(A)-*S-1.27-DSA(L)

FX2-*S-1.27SV(L)

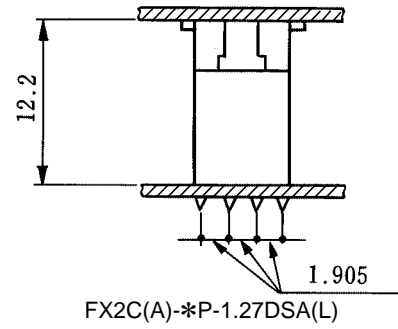

FX2C(A)-*P-1.27DSA(L)

FX2-*S-1.27SV(L)

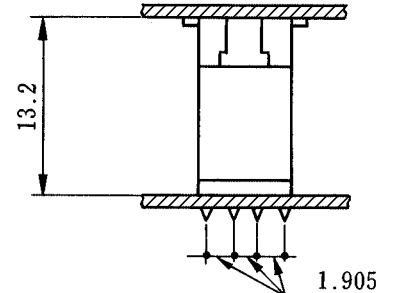

FX2C(A)1-*P-1.27DSA(L)

FX2-*P-1.27SV(L)

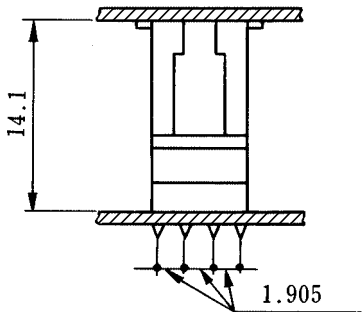

FX2C(A)2-*S-1.27DSA(L)

FX2-*S-1.27SV(L)

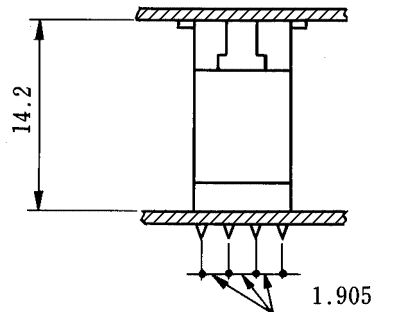

FX2C(A)2-*P-1.27DSA(L)

FX2-*P-1.27SV(L)

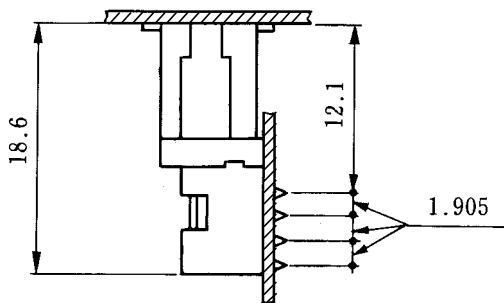

FX2-*S-1.27DS(L)

FX2-*S-1.27SV(L)

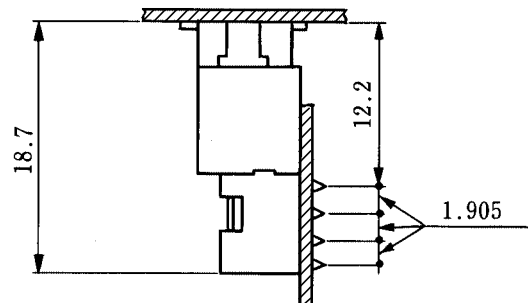

FX2-*P-1.27DS(L)

◆ SMT Type Application Pattern

FX2(A)-*P-0.635SH

Receptacle	A
FX2C(A)2	14.7
FX2C(A)2	16.7

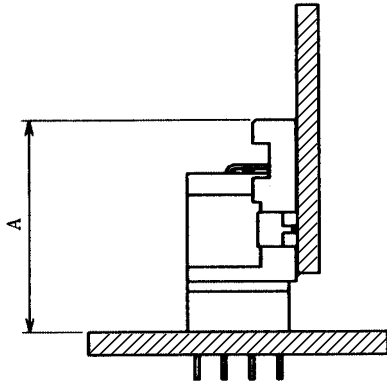

FX2(A)-*P-0.635SH

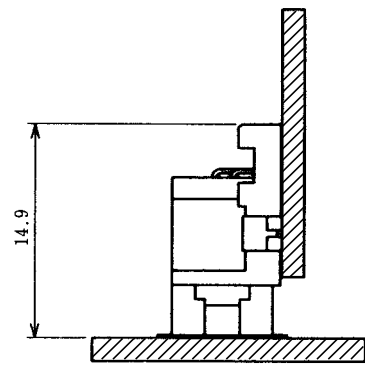

FX2C(A*2)-*S-1.27DSA(L)

FX2-*S-1.27SV(L)

FX2(A)-*P-0.635SH

FX2(A)-*P-0.635SH

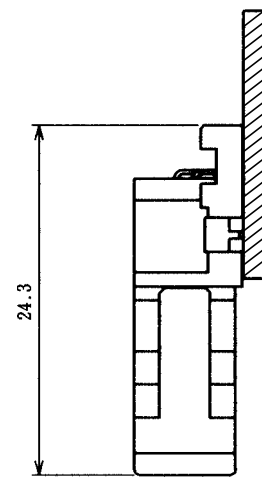
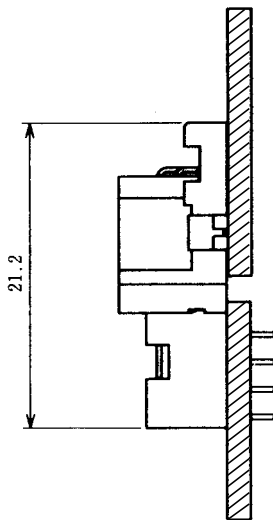

FX2-*S-1.27DS(L)

FX2BA-*SA-1.27R

■Receptacle No Cleaning Type

●Straight Type

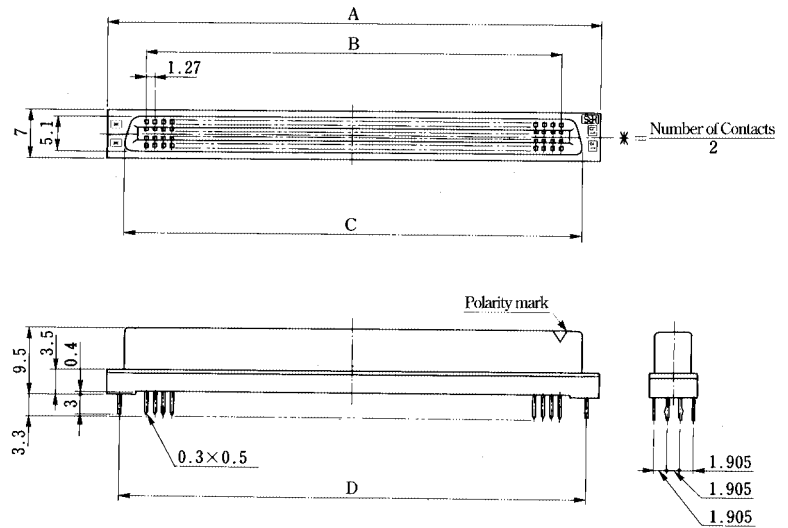
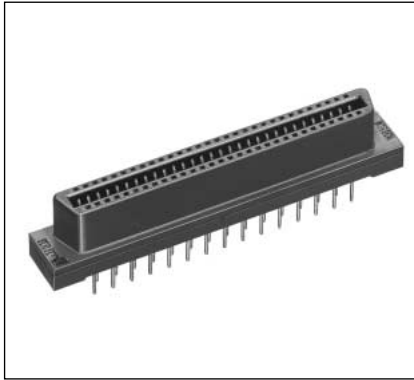

◆PCB mounting pattern

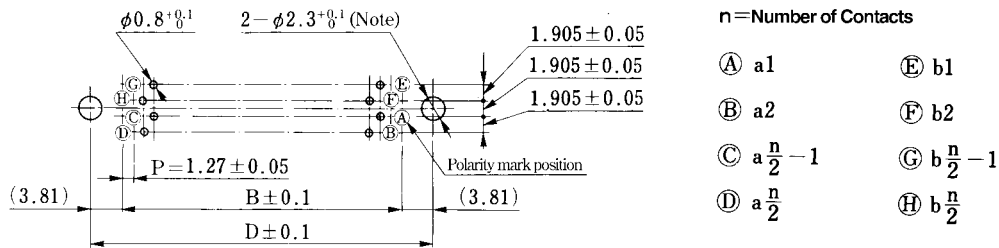

Note: Not required, if no prefixed pin is attached.

Unit:mm

Part Number	CL No.	Number of Contacts	A	B	C	D
FX2C- 20S-1.27DSA	572-2401-7	20	22.75	11.43	17.63	_____
FX2C- 20S-1.27DSAL	572-2451-5					19.05
FX2C- 32S-1.27DSA	572-2402-0	32	30.37	19.05	25.25	_____
FX2C- 32S-1.27DSAL	572-2452-8					26.67
FX2C- 40S-1.27DSA	572-2403-2	40	35.45	24.13	30.33	_____
FX2C- 40S-1.27DSAL	572-2453-0					31.75
FX2C- 52S-1.27DSA	572-2404-5	52	43.07	31.75	37.95	_____
FX2C- 52S-1.27DSAL	572-2454-3					39.37
FX2C- 60S-1.27DSA	572-2405-8	60	48.15	36.83	43.03	_____
FX2C- 60S-1.27DSAL	572-2455-6					44.45
FX2C- 68S-1.27DSA	572-2406-0	68	53.23	41.91	48.11	_____
FX2C- 68S-1.27DSAL	572-2456-9					49.53
FX2C- 80S-1.27DSA	572-2407-3	80	60.85	49.53	55.73	_____
FX2C- 80S-1.27DSAL	572-2457-1					57.15
FX2C-100S-1.27DSA	572-2408-6	100	73.55	62.23	68.43	_____
FX2C-100S-1.27DSAL	572-2458-4					69.85
FX2C-120S-1.27DSA	572-2409-9	120	86.25	74.93	81.13	_____
FX2C-120S-1.27DSAL	572-2459-7					82.55

■Receptacle Cleaning Type

●Straight Type

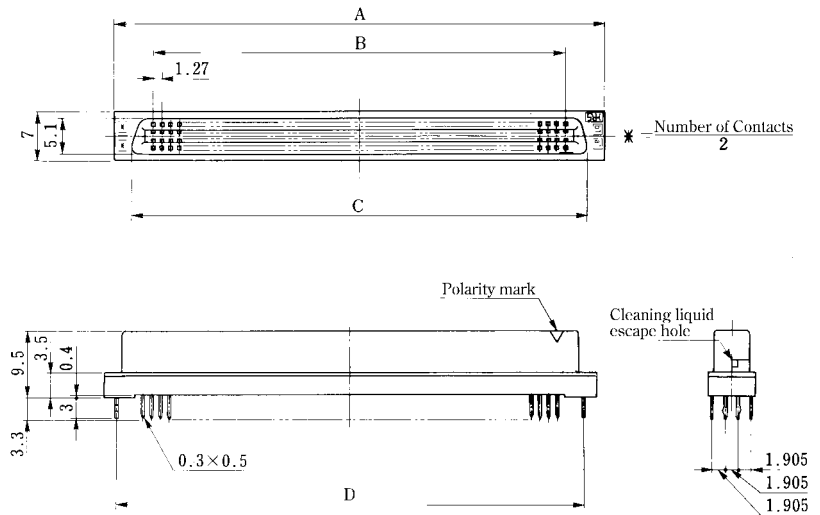
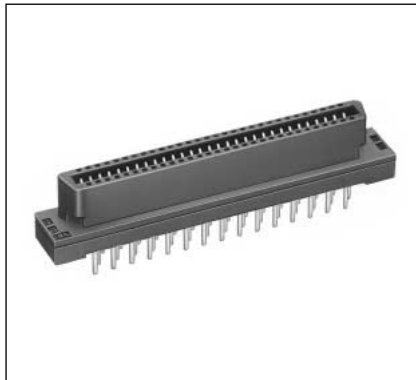

◆PCB mounting pattern

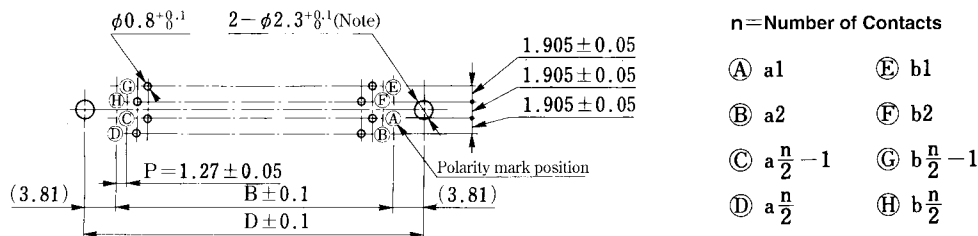

Note: Not required, if no prefixed pin is attached.

Unit:mm

Part Number	CL No.	Number of Contacts	A	B	C	D
FX2CA- 20S-1.27DSA	572-2501-1	20	22.75	11.43	17.63	_____
FX2CA- 20S-1.27DSAL	572-2551-0					19.05
FX2CA- 32S-1.27DSA	572-2502-4	32	30.37	19.05	25.25	_____
FX2CA- 32S-1.27DSAL	572-2552-2					26.67
FX2CA- 40S-1.27DSA	572-2503-7	40	35.45	24.13	30.33	_____
FX2CA- 40S-1.27DSAL	572-2553-5					31.75
FX2CA- 52S-1.27DSA	572-2504-0	52	43.07	31.75	37.95	_____
FX2CA- 52S-1.27DSAL	572-2554-8					39.37
FX2CA- 60S-1.27DSA	572-2505-2	60	48.15	36.83	43.03	_____
FX2CA- 60S-1.27DSAL	572-2555-0					44.45
FX2CA- 68S-1.27DSA	572-2506-5	68	53.23	41.91	48.11	_____
FX2CA- 68S-1.27DSAL	572-2556-3					49.53
FX2CA- 80S-1.27DSA	572-2507-8	80	60.85	49.53	55.73	_____
FX2CA- 80S-1.27DSAL	572-2557-6					57.15
FX2CA-100S-1.27DSA	572-2508-0	100	73.55	62.23	68.43	_____
FX2CA-100S-1.27DSAL	572-2558-9					69.85
FX2CA-120S-1.27DSA	572-2509-3	120	86.25	74.93	81.13	_____
FX2CA-120S-1.27DSAL	572-2559-1					82.55

■Receptacle No Cleaning Type

●Straight Type

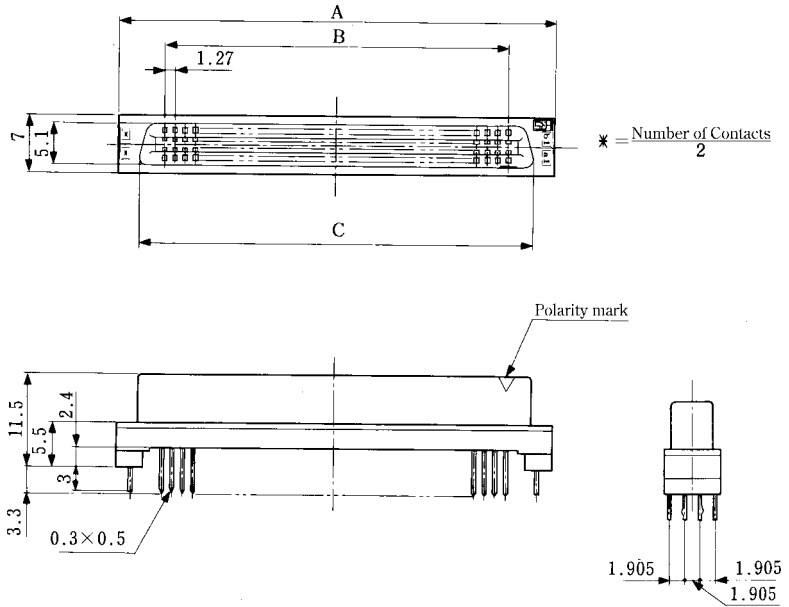
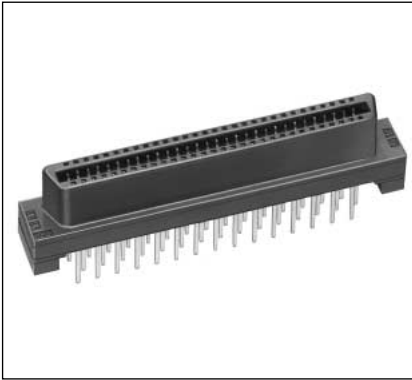

◆PCB mounting pattern

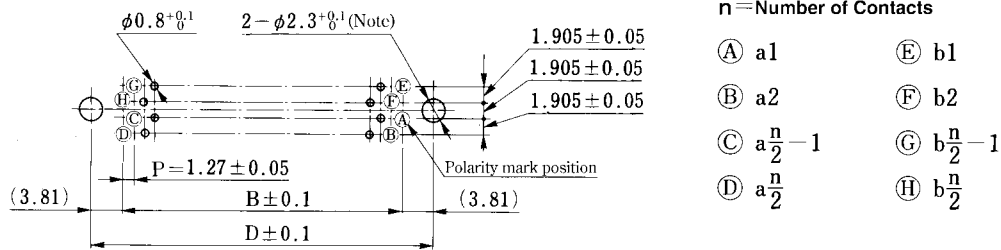

Note: Not required, if no prefixed pin is attached.

Unit:mm

Part Number	CL No.	Number of Contacts	A	B	C	D
FX2C2- 20S-1.27DSA	572-2421-4	20	22.75	11.43	17.63	_____
FX2C2- 20S-1.27DSAL	572-2471-2					19.05
FX2C2- 32S-1.27DSA	572-2422-7	32	30.37	19.05	25.25	_____
FX2C2- 32S-1.27DSAL	572-2472-5					26.67
FX2C2- 40S-1.27DSA	572-2423-0	40	35.45	24.13	30.33	_____
FX2C2- 40S-1.27DSAL	572-2473-8					31.75
FX2C2- 52S-1.27DSA	572-2424-2	52	43.07	31.75	37.95	_____
FX2C2- 52S-1.27DSAL	572-2474-0					39.37
FX2C2- 60S-1.27DSA	572-2425-5	60	48.15	36.83	43.03	_____
FX2C2- 60S-1.27DSAL	572-2475-3					44.45
FX2C2- 68S-1.27DSA	572-2426-8	68	53.23	41.91	48.11	_____
FX2C2- 68S-1.27DSAL	572-2476-6					49.53
FX2C2- 80S-1.27DSA	572-2427-0	80	60.85	49.53	55.73	_____
FX2C2- 80S-1.27DSAL	572-2477-9					57.15
FX2C2-100S-1.27DSA	572-2428-3	100	73.55	62.23	68.43	_____
FX2C2-100S-1.27DSAL	572-2478-1					69.85
FX2C2-120S-1.27DSA	572-2429-6	120	86.25	74.93	81.13	_____
FX2C2-120S-1.27DSAL	572-2479-4					82.55

■ Receptacle Cleaning Type

● Straight Type

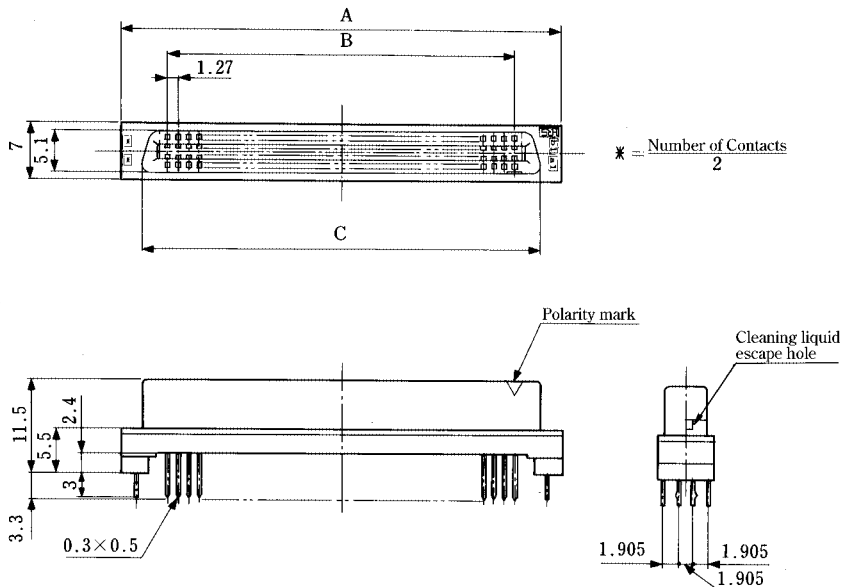
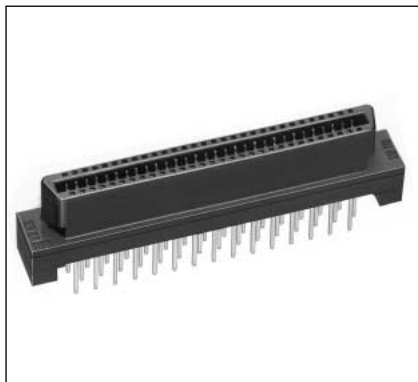

◆ PCB mounting pattern

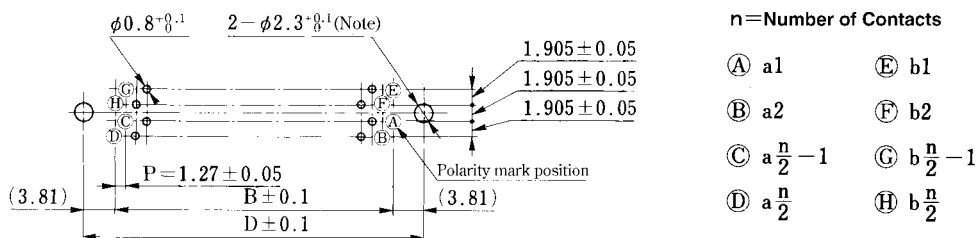

Note: Not required, if no prefixed pin is attached.

Unit:mm

Part Number	CL No.	Number of Contacts	A	B	C	D
FX2CA2- 20S-1.27DSA	572-2521-9	20	22.75	11.43	17.63	_____
FX2CA2- 20S-1.27DSAL	572-2571-7					19.05
FX2CA2- 32S-1.27DSA	572-2522-1	32	30.37	19.05	25.25	_____
FX2CA2- 32S-1.27DSAL	572-2572-0					26.67
FX2CA2- 40S-1.27DSA	572-2523-4	40	35.45	24.13	30.33	_____
FX2CA2- 40S-1.27DSAL	572-2573-2					31.75
FX2CA2- 52S-1.27DSA	572-2524-7	52	43.07	31.75	37.95	_____
FX2CA2- 52S-1.27DSAL	572-2574-5					39.37
FX2CA2- 60S-1.27DSA	572-2525-0	60	48.15	36.83	43.03	_____
FX2CA2- 60S-1.27DSAL	572-2575-8					44.45
FX2CA2- 68S-1.27DSA	572-2526-2	68	53.23	41.91	48.11	_____
FX2CA2- 68S-1.27DSAL	572-2576-0					49.53
FX2CA2- 80S-1.27DSA	572-2527-5	80	60.85	49.53	55.73	_____
FX2CA2- 80S-1.27DSAL	572-2577-3					57.15
FX2CA2-100S-1.27DSA	572-2528-8	100	73.55	62.23	68.43	_____
FX2CA2-100S-1.27DSAL	572-2578-6					69.85
FX2CA2-120S-1.27DSA	572-2529-0	120	86.25	74.93	81.13	_____
FX2CA2-120S-1.27DSAL	572-2579-9					82.55

■ Receptacle

● Right Angle Type

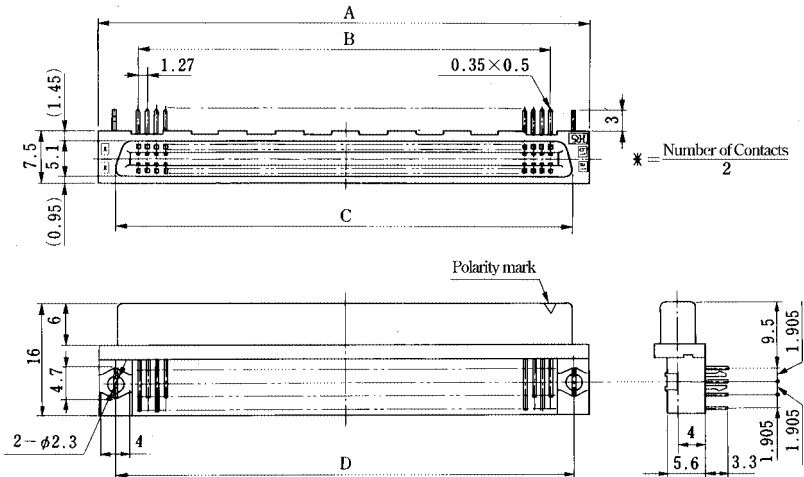

◆ PCB mounting pattern

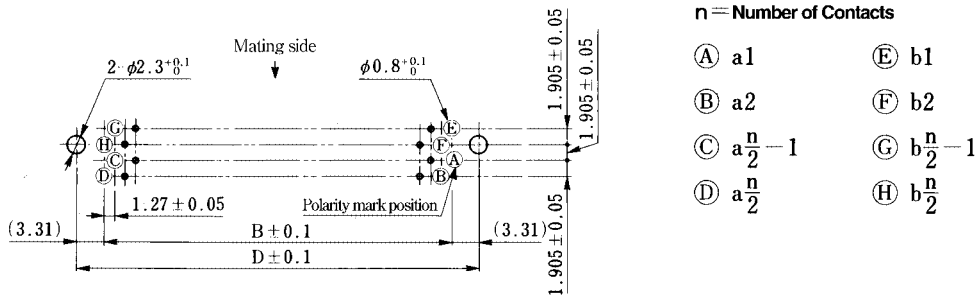

Unit:mm

Part Number	CL No.	Number of Contacts	A	B	C	D
FX2- 20S-1.27DS	572-2701-0	20	22.75	11.43	17.63	18.05
FX2- 20S-1.27DSL	572-2751-9					
FX2- 32S-1.27DS	572-2702-3	32	30.37	19.05	25.25	25.67
FX2- 32S-1.27DSL	572-2752-1					
FX2- 40S-1.27DS	572-2703-6	40	35.45	24.13	30.33	30.75
FX2- 40S-1.27DSL	572-2753-4					
FX2- 52S-1.27DS	572-2704-9	52	43.07	31.75	37.95	38.37
FX2- 52S-1.27DSL	572-2754-7					
FX2- 60S-1.27DS	572-2705-1	60	48.15	36.83	43.03	43.45
FX2- 60S-1.27DSL	572-2755-0					
FX2- 68S-1.27DS	572-2706-4	68	53.23	41.91	48.11	48.53
FX2- 68S-1.27DSL	572-2756-2					
FX2- 80S-1.27DS	572-2707-7	80	60.85	49.53	55.73	56.15
FX2- 80S-1.27DSL	572-2757-5					
FX2-100S-1.27DS	572-2708-0	100	73.55	62.23	68.43	68.85
FX2-100S-1.27DSL	572-2758-8					
FX2-120S-1.27DS	572-2709-2	120	86.25	74.93	81.13	81.55
FX2-120S-1.27DSL	572-2759-0					

Header

Right Angle Type

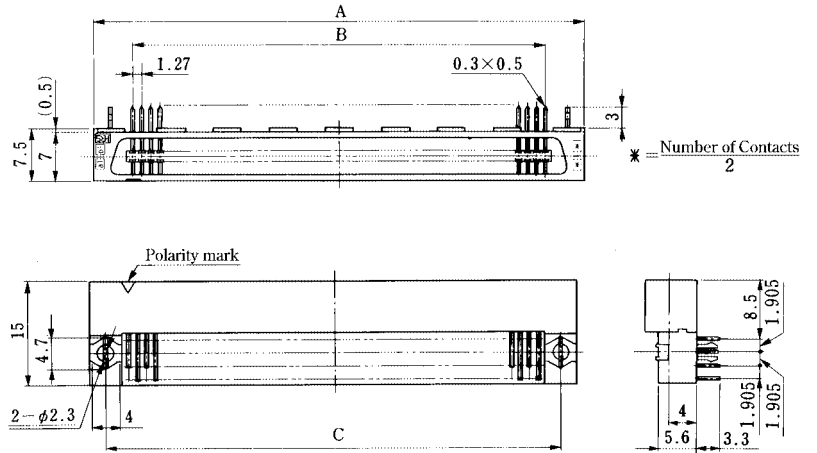
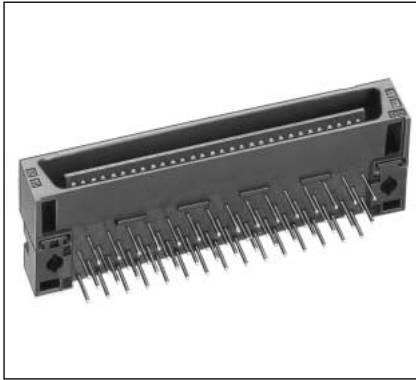

PCB mounting pattern

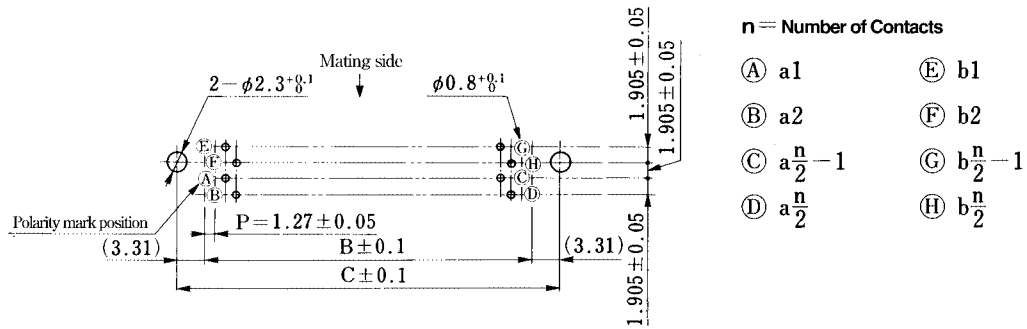

Unit:mm

Part Number	CL No.	Number of Contacts	A	B	C
FX2- 20P-1.27DS	572-2601-6	20	22.75	11.43	18.05
FX2- 20P-1.27DSL	572-2651-4				
FX2- 32P-1.27DS	572-2602-9	32	30.37	19.05	25.67
FX2- 32P-1.27DSL	572-2652-7				
FX2- 40P-1.27DS	572-2603-1	40	35.45	24.13	30.75
FX2- 40P-1.27DSL	572-2653-0				
FX2- 52P-1.27DS	572-2604-4	52	43.07	31.75	38.37
FX2- 52P-1.27DSL	572-2654-2				
FX2- 60P-1.27DS	572-2605-7	60	48.15	36.83	43.45
FX2- 60P-1.27DSL	572-2655-5				
FX2- 68P-1.27DS	572-2606-0	68	53.23	41.91	48.53
FX2- 68P-1.27DSL	572-2656-8				
FX2- 80P-1.27DS	572-2607-2	80	60.85	49.53	56.15
FX2- 80P-1.27DSL	572-2657-0				
FX2-100P-1.27DS	572-2608-5	100	73.55	62.23	68.85
FX2-100P-1.27DSL	572-2658-3				
FX2-120P-1.27DS	572-2609-8	120	86.25	74.93	81.55
FX2-120P-1.27DSL	572-2659-6				

Header No Cleaning Type

●Straight Type

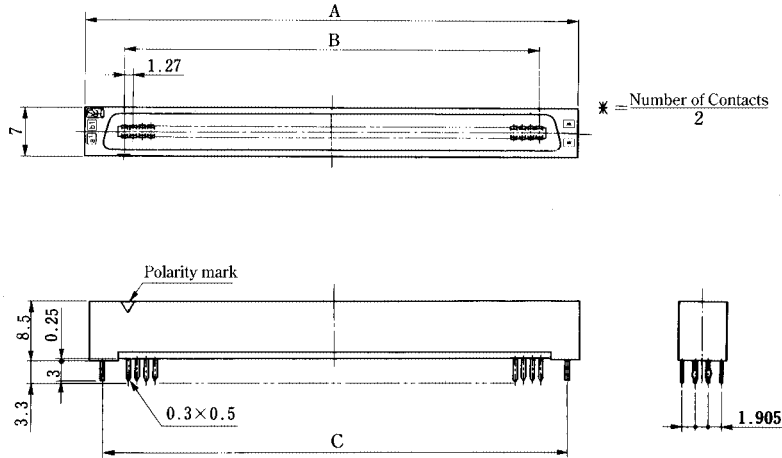
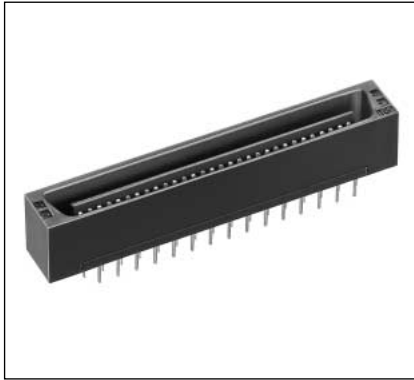

◆PCB mounting pattern

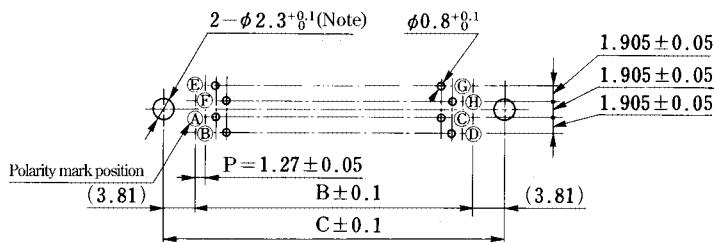

n = Number of Contacts

- Ⓐ a1 Ⓔ b1
- Ⓑ a2 Ⓕ b2
- Ⓒ $a\frac{n}{2}-1$ Ⓖ $b\frac{n}{2}-1$
- Ⓓ $a\frac{n}{2}$ Ⓖ $b\frac{n}{2}$

Note: Not required, if no prefixed pin is attached.

Unit:mm

Part Number	CL No.	Number of Contacts	A	B	C
FX2C- 20P-1.27DSA	572-2201-8	20	22.75	11.43	_____
FX2C- 20P-1.27DSAL	572-2251-6				19.05
FX2C- 32P-1.27DSA	572-2202-0	32	30.37	19.05	_____
FX2C- 32P-1.27DSAL	572-2252-9				26.67
FX2C- 40P-1.27DSA	572-2203-3	40	35.45	24.13	_____
FX2C- 40P-1.27DSAL	572-2253-1				31.75
FX2C- 52P-1.27DSA	572-2204-6	52	43.07	31.75	_____
FX2C- 52P-1.27DSAL	572-2254-4				39.37
FX2C- 60P-1.27DSA	572-2205-9	60	48.15	36.83	_____
FX2C- 60P-1.27DSAL	572-2255-7				44.45
FX2C- 68P-1.27DSA	572-2206-1	68	53.23	41.91	_____
FX2C- 68P-1.27DSAL	572-2256-0				49.53
FX2C- 80P-1.27DSA	572-2207-4	80	60.85	49.53	_____
FX2C- 80P-1.27DSAL	572-2257-2				57.15
FX2C-100P-1.27DSA	572-2208-7	100	73.55	62.23	_____
FX2C-100P-1.27DSAL	572-2258-5				69.85
FX2C-120P-1.27DSA	572-2209-0	120	86.25	74.93	_____
FX2C-120P-1.27DSAL	572-2259-8				82.55

Header Cleaning Type

●Straight Type

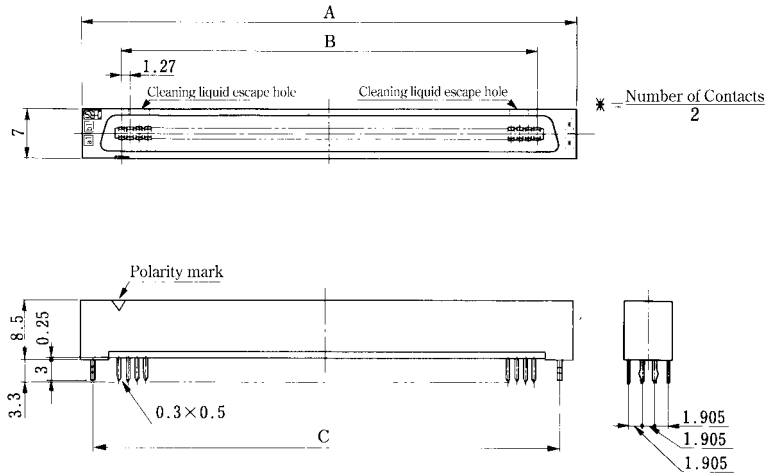
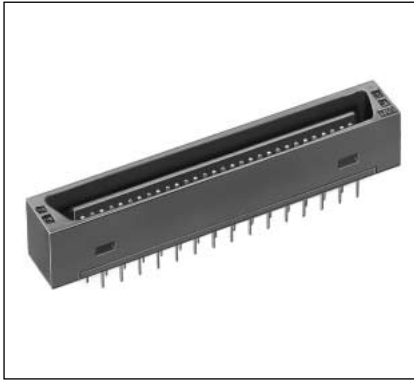

◆PCB mounting pattern

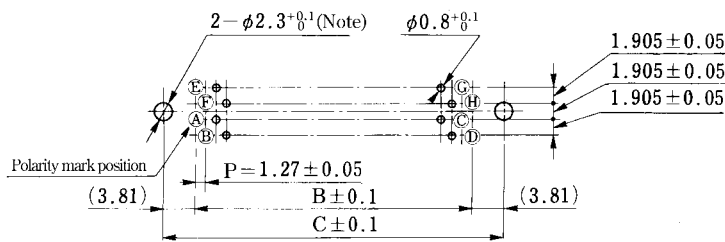

n = Number of Contacts

- Ⓐ a1 Ⓔ b1
- Ⓑ a2 Ⓕ b2
- Ⓒ $a \frac{n}{2} - 1$ Ⓖ $b \frac{n}{2} - 1$
- Ⓓ $a \frac{n}{2}$ Ⓖ $b \frac{n}{2}$

Note: Not required, if no prefixed pin is attached.

Unit:mm

Part Number	CL No.	Number of Contacts	A	B	C
FX2CA- 20P-1.27DSA	572-2301-2	20	22.75	11.43	_____
FX2CA- 20P-1.27DSAL	572-2351-0				19.05
FX2CA- 32P-1.27DSA	572-2302-5	32	30.37	19.05	_____
FX2CA- 32P-1.27DSAL	572-2352-3				26.67
FX2CA- 40P-1.27DSA	572-2303-8	40	35.45	24.13	_____
FX2CA- 40P-1.27DSAL	572-2353-6				31.75
FX2CA- 52P-1.27DSA	572-2304-0	52	43.07	31.75	_____
FX2CA- 52P-1.27DSAL	572-2354-9				39.37
FX2CA- 60P-1.27DSA	572-2305-3	60	48.15	36.83	_____
FX2CA- 60P-1.27DSAL	572-2355-1				44.45
FX2CA- 68P-1.27DSA	572-2306-6	68	53.23	41.91	_____
FX2CA- 68P-1.27DSAL	572-2356-4				49.53
FX2CA- 80P-1.27DSA	572-2307-9	80	60.85	49.53	_____
FX2CA- 80P-1.27DSAL	572-2357-7				57.15
FX2CA-100P-1.27DSA	572-2308-1	100	73.55	62.23	_____
FX2CA-100P-1.27DSAL	572-2358-0				69.85
FX2CA-120P-1.27DSA	572-2309-4	120	86.25	74.93	_____
FX2CA-120P-1.27DSAL	572-2359-2				82.55

Header No Cleaning Type

●Straight Type

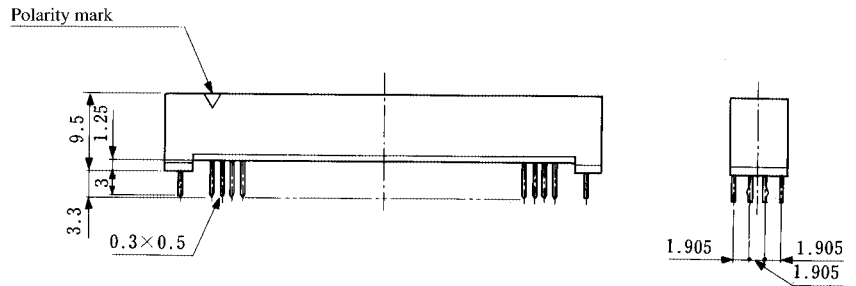
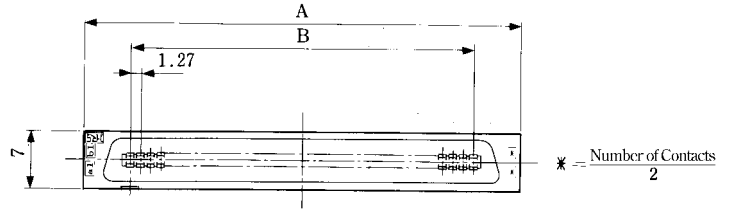
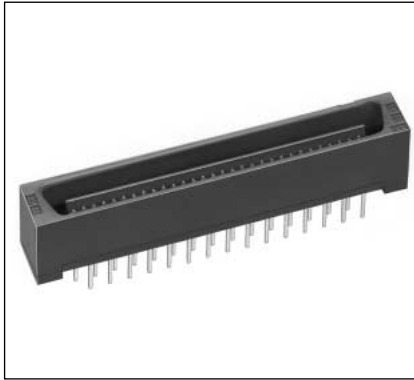

◆PCB mounting pattern

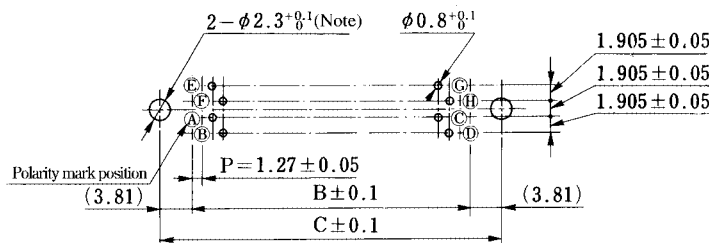

- n = Number of Contacts**
- Ⓐ a1 Ⓔ b1
 - Ⓑ a2 Ⓕ b2
 - Ⓒ $a\frac{n}{2} - 1$ Ⓖ $b\frac{n}{2} - 1$
 - Ⓓ $a\frac{n}{2}$ Ⓗ $b\frac{n}{2}$

Note: Not required, if no prefixed pin is attached.

Unit: mm

Part Number	CL No.	Number of Contacts	A	B	C
FX2C1- 20P-1.27DSA	572-2211-1	20	22.75	11.43	—
FX2C1- 20P-1.27DSAL	572-2261-0				19.05
FX2C1- 32P-1.27DSA	572-2212-4	32	30.37	19.05	—
FX2C1- Z32P-1.27DSAL	572-2262-2				26.67
FX2C1- 40P-1.27DSA	572-2213-7	40	35.45	24.13	—
FX2C1- 40P-1.27DSAL	572-2263-5				31.75
FX2C1- 52P-1.27DSA	572-2214-0	52	43.07	31.75	—
FX2C1- 52P-1.27DSAL	572-2264-8				39.37
FX2C1- 60P-1.27DSA	572-2215-2	60	48.15	36.83	—
FX2C1- 60P-1.27DSAL	572-2265-0				44.45
FX2C1- 68P-1.27DSA	572-2216-5	68	53.23	41.91	—
FX2C1- 68P-1.27DSAL	572-2266-3				49.53
FX2C1- 80P-1.27DSA	572-2217-8	80	60.85	49.53	—
FX2C1- 80P-1.27DSAL	572-2267-6				57.15
FX2C1-100P-1.27DSA	572-2218-0	100	73.55	62.23	—
FX2C1-100P-1.27DSAL	572-2268-9				69.85
FX2C1-120P-1.27DSA	572-2219-3	120	86.25	74.93	—
FX2C1-120P-1.27DSAL	572-2269-1				82.55

Header Cleaning Type

●Straight Type

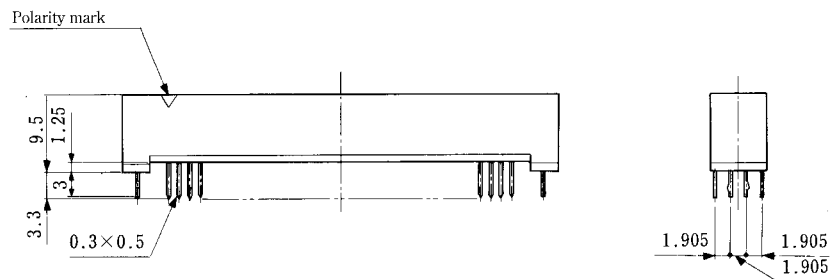
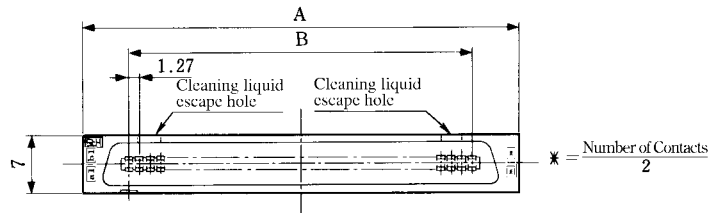
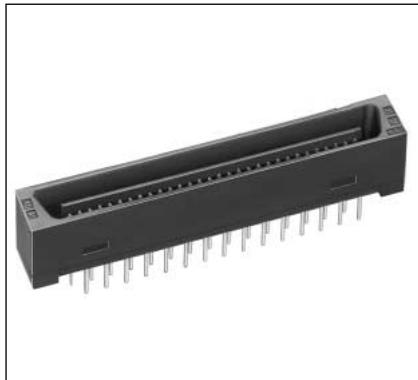

◆PCB mounting pattern

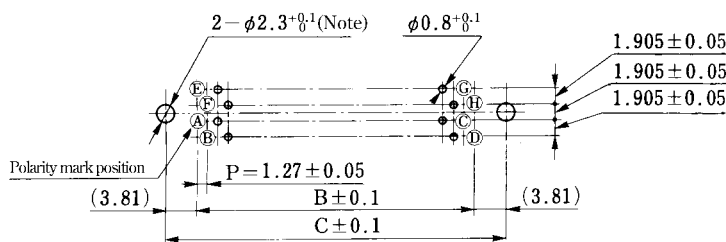

n = Number of Contacts

- Ⓐ a1 Ⓔ b1
- Ⓑ a2 Ⓕ b2
- Ⓒ $\frac{n}{2} - 1$ Ⓖ $\frac{n}{2} - 1$
- Ⓓ $\frac{n}{2}$ Ⓖ $\frac{n}{2}$

Note: Not required, if no prefixed pin is attached.

Unit: mm

Part Number	CL No.	Number of Contacts	A	B	C
FX2CA1- 20P-1.27DSA	572-2311-6	20	22.75	11.43	—
FX2CA1- 20P-1.27DSAL	572-2361-4				19.05
FX2CA1- 32P-1.27DSA	572-2312-9	32	30.37	19.05	—
FX2CA1- 32P-1.27DSAL	572-2362-7				26.67
FX2CA1- 40P-1.27DSA	572-2313-1	40	35.45	24.13	—
FX2CA1- 40P-1.27DSAL	572-2363-0				31.75
FX2CA1- 52P-1.27DSA	572-2314-4	52	43.07	31.75	—
FX2CA1- 52P-1.27DSAL	572-2364-2				39.37
FX2CA1- 60P-1.27DSA	572-2315-7	60	48.15	36.83	—
FX2CA1- 60P-1.27DSAL	572-2365-5				44.45
FX2CA1- 68P-1.27DSA	572-2316-0	68	53.23	41.91	—
FX2CA1- 68P-1.27DSAL	572-2366-8				49.53
FX2CA1- 80P-1.27DSA	572-2317-2	80	60.85	49.53	—
FX2CA1- 80P-1.27DSAL	572-2367-0				57.15
FX2CA1-100P-1.27DSA	572-2318-5	100	73.55	62.23	—
FX2CA1-100P-1.27DSAL	572-2368-3				69.85
FX2CA1-120P-1.27DSA	572-2319-8	120	86.25	74.93	—
FX2CA1-120P-1.27DSAL	572-2369-6				82.55

Header No Cleaning Type

●Straight Type

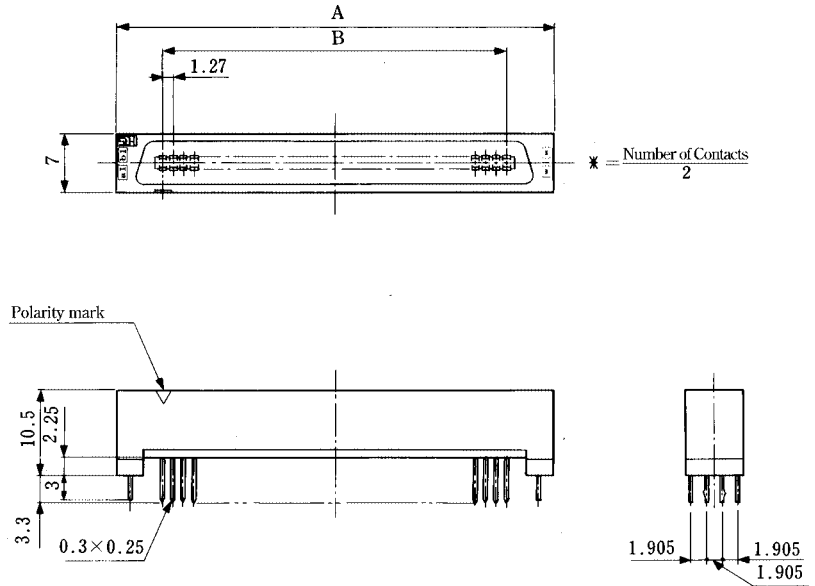
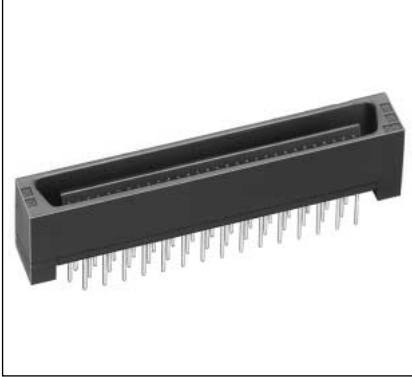

◆PCB mounting pattern

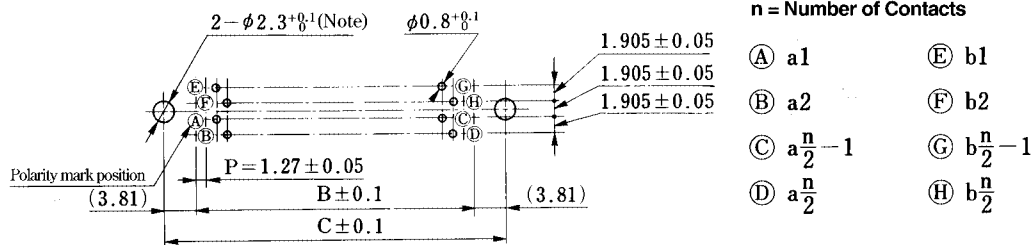

Note: Not required, if no prefixed pin is attached.

Unit: mm

Part Number	CL No.	Number of Contacts	A	B	C
FX2C2- 20P-1.27DSA	572-2221-5	20	22.75	11.43	—
FX2C2- 20P-1.27DSAL	572-2271-3				19.05
FX2C2- 32P-1.27DSA	572-2222-8	32	30.37	19.05	—
FX2C2- 32P-1.27DSAL	572-2272-6				26.67
FX2C2- 40P-1.27DSA	572-2223-0	40	35.45	24.13	—
FX2C2- 40P-1.27DSAL	572-2273-9				31.75
FX2C2- 52P-1.27DSA	572-2224-3	52	43.07	31.75	—
FX2C2- 52P-1.27DSAL	572-2274-1				39.37
FX2C2- 60P-1.27DSA	572-2225-6	60	48.15	36.83	—
FX2C2- 60P-1.27DSAL	572-2275-4				44.45
FX2C2- 68P-1.27DSA	572-2226-9	68	53.23	41.91	—
FX2C2- 68P-1.27DSAL	572-2276-7				49.53
FX2C2- 80P-1.27DSA	572-2227-1	80	60.85	49.53	—
FX2C2- 80P-1.27DSAL	572-2277-0				57.15
FX2C2-100P-1.27DSA	572-2228-4	100	73.55	62.23	—
FX2C2-100P-1.27DSAL	572-2278-2				69.85
FX2C2-120P-1.27DSA	572-2229-7	120	86.25	74.93	—
FX2C2-120P-1.27DSAL	572-2279-5				82.55

Header Cleaning Type

Straight Type

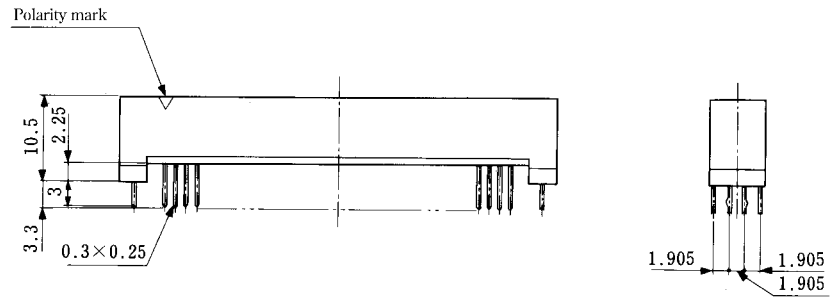
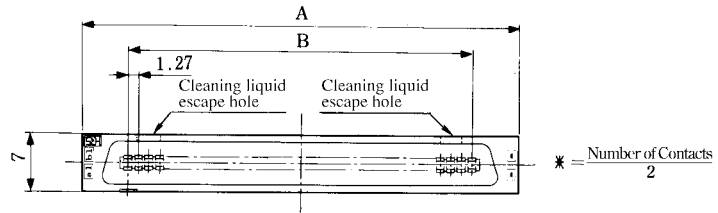

PCB mounting pattern

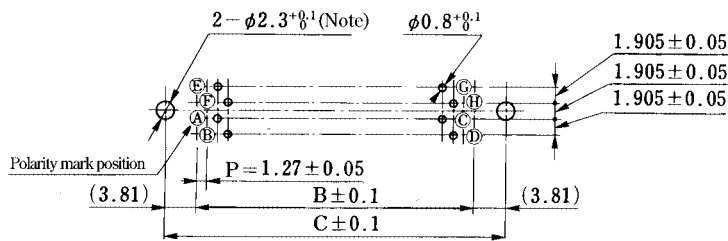

n = Number of Contacts

- Ⓐ a1
- Ⓑ a2
- Ⓒ $a \frac{n}{2} - 1$
- Ⓓ $a \frac{n}{2}$
- Ⓔ b1
- Ⓕ b2
- Ⓖ $b \frac{n}{2} - 1$
- Ⓗ $b \frac{n}{2}$

Note: Not required, if no prefixed pin is attached.

Unit: mm

Part Number	CL No.	Number of Contacts	A	B	C
FX2CA2- 20P-1.27DSA	572-2321-0	20	22.75	11.43	—
FX2CA2- 20P-1.27DSAL	572-2371-8				19.05
FX2CA2- 32P-1.27DSA	572-2322-2	32	30.37	19.05	—
FX2CA2- 32P-1.27DSAL	572-2372-0				26.67
FX2CA2- 40P-1.27DSA	572-2323-5	40	35.45	24.13	—
FX2CA2- 40P-1.27DSAL	572-2373-3				31.75
FX2CA2- 52P-1.27DSA	572-2324-8	52	43.07	31.75	—
FX2CA2- 52P-1.27DSAL	572-2374-6				39.37
FX2CA2- 60P-1.27DSA	572-2325-0	60	48.15	36.83	—
FX2CA2- 60P-1.27DSAL	572-2375-9				44.45
FX2CA2- 68P-1.27DSA	572-2326-3	68	53.23	41.91	—
FX2CA2- 68P-1.27DSAL	572-2376-1				49.53
FX2CA2- 80P-1.27DSA	572-2327-6	80	60.85	49.53	—
FX2CA2- 80P-1.27DSAL	572-2377-4				57.15
FX2CA2-100P-1.27DSA	572-2328-9	100	73.55	62.23	—
FX2CA2-100P-1.27DSAL	572-2378-7				69.85
FX2CA2-120P-1.27DSA	572-2329-1	120	86.25	74.93	—
FX2CA2-120P-1.27DSAL	572-2379-0				82.55

■Receptacle SMT Type

●Straight Type

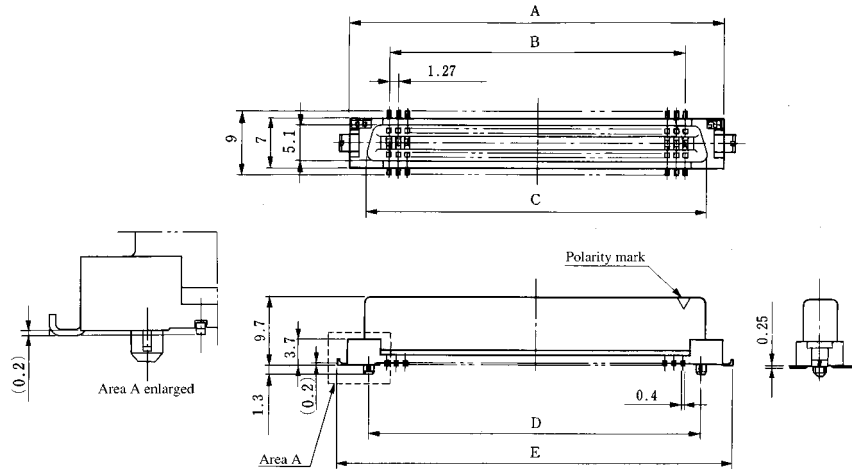
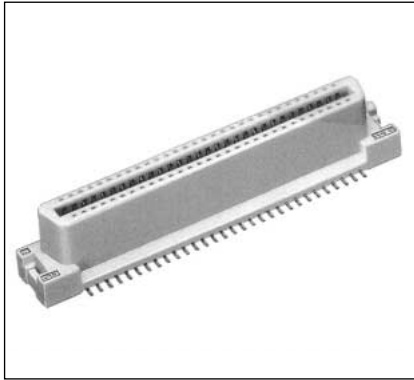

Note: The 120 contacts type differs in the style.

◆PCB mounting pattern

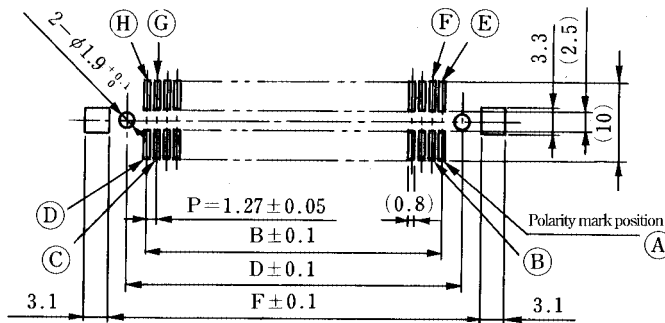

n = Number of Contacts

- Ⓐ a1 Ⓔ b1
- Ⓑ a2 Ⓕ b2
- Ⓒ $a\frac{n}{2} - 1$ Ⓖ $b\frac{n}{2} - 1$
- Ⓓ $a\frac{n}{2}$ Ⓖ $b\frac{n}{2}$

Unit: mm

Part Number	CL No.	Number of Contacts	A	B	C	D	E	F
FX2- 20S-1.27SV	572-2101-3	20	22.75	11.43	17.63	16.51	—	—
FX2- 20S-1.27SVL	572-2151-1						25.75	21.15
FX2- 32S-1.27SV	572-2102-6	32	30.37	19.05	25.25	24.13	—	—
FX2- 32S-1.27SVL	572-2152-4						33.37	28.77
FX2- 40S-1.27SV	572-2103-9	40	35.45	24.13	30.33	29.21	—	—
FX2- 40S-1.27SVL	572-2153-7						38.45	33.85
FX2- 52S-1.27SV	572-2104-1	52	43.07	31.75	37.95	36.83	—	—
FX2- 52S-1.27SVL	572-2154-0						46.07	41.47
FX2- 60S-1.27SV	572-2105-4	60	48.15	36.83	43.03	41.91	—	—
FX2- 60S-1.27SVL	572-2155-2						51.15	46.55
FX2- 68S-1.27SV	572-2106-7	68	53.23	41.91	48.11	46.99	—	—
FX2- 68S-1.27SVL	572-2156-5						56.23	51.63
FX2- 80S-1.27SV	572-2107-0	80	60.85	49.53	55.73	54.61	—	—
FX2- 80S-1.27SVL	572-2157-8						63.85	59.25
FX2-100S-1.27SV	572-2108-2	100	73.55	62.23	68.43	67.31	—	—
FX2-100S-1.27SVL	572-2158-0						76.55	71.95
FX2-120S-1.27SV	572-2109-5	120	86.25	74.93	81.13	80.01	—	—
FX2-120S-1.27SVL	572-2159-3						89.25	84.65

Header SMT Type

●Straight Type

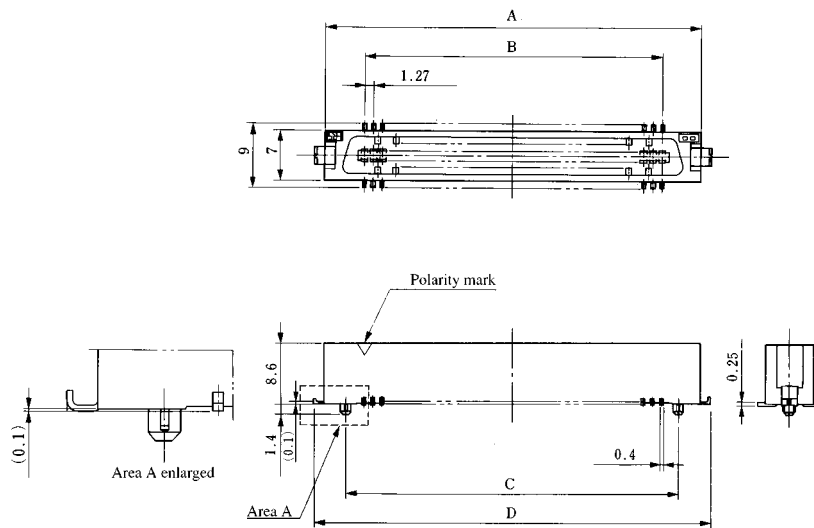

◆PCB mounting pattern

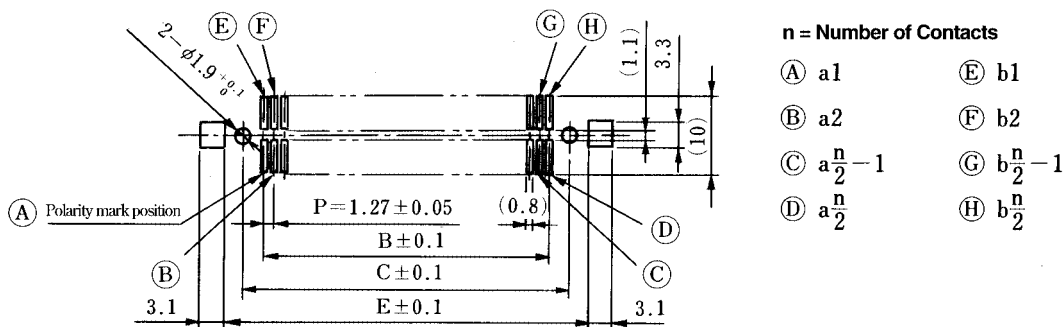

Unit: mm

Part Number	CL No.	Number of Contacts	A	B	C	D	E
FX2- 20P-1.27SV	572-2001-9	20	22.75	11.43	16.51	—	—
FX2- 20P-1.27SVL	572-2051-7					25.75	21.15
FX2- 32P-1.27SV	572-2002-1	32	30.37	19.05	24.13	—	—
FX2- 32P-1.27SVL	572-2052-0					33.37	28.77
FX2- 40P-1.27SV	572-2003-4	40	35.45	24.13	29.21	—	—
FX2- 40P-1.27SVL	572-2053-2					38.45	33.85
FX2- 52P-1.27SV	572-2004-7	52	43.07	31.75	36.83	—	—
FX2- 52P-1.27SVL	572-2054-5					46.07	41.47
FX2- 60P-1.27SV	572-2005-0	60	48.15	36.83	41.91	—	—
FX2- 60P-1.27SVL	572-2055-8					51.15	46.55
FX2- 68P-1.27SV	572-2006-2	68	53.23	41.91	46.99	—	—
FX2- 68P-1.27SVL	572-2056-0					56.23	51.63
FX2- 80P-1.27SV	572-2007-5	80	60.85	49.53	54.61	—	—
FX2- 80P-1.27SVL	572-2057-3					63.85	59.25
FX2-100P-1.27SV	572-2008-8	100	73.55	62.23	67.31	—	—
FX2-100P-1.27SVL	572-2058-6					76.55	71.95
FX2-120P-1.27SV	572-2009-0	120	86.25	74.93	80.01	—	—
FX2-120P-1.27SVL	572-2059-9					89.25	84.65

Header SMT Type

Right Angle Type

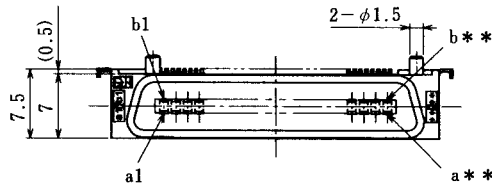
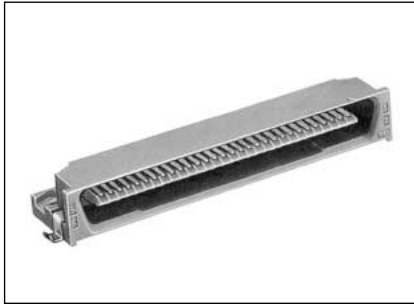

$$** = \frac{\text{Number of Contacts}}{2}$$

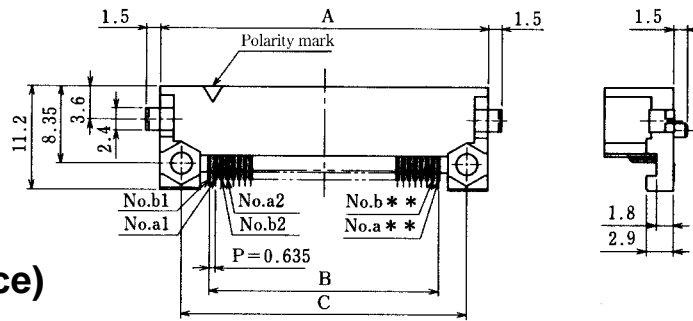

Mounting Example (Reference)

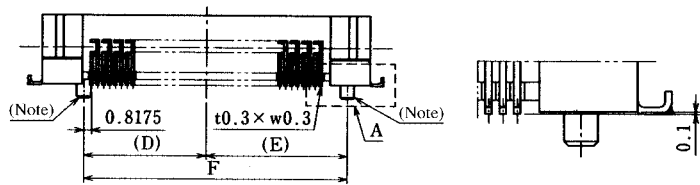
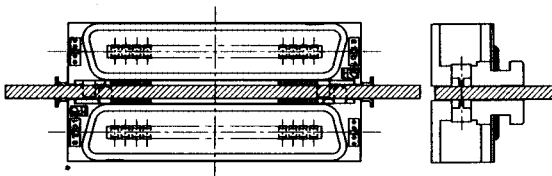

Since bosses are located symmetrically on the right and left sides, connectors can be mounted on both sides of board as shown above.

Note: The FX2A type does not have bosses as shown in the illustration.

PCB mounting Pattern

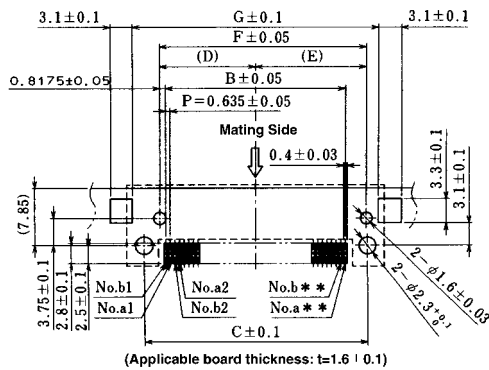

Recommended Screw Clamp

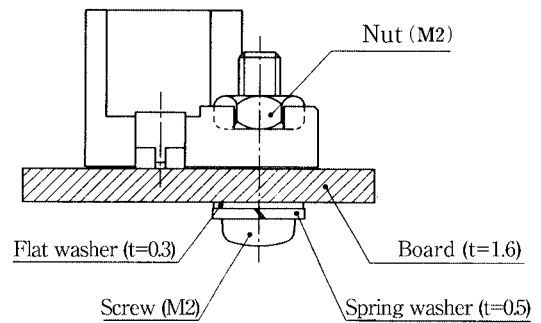

Use M2 screw for fixture.
Recommended torque is 0.15(N•m).

Unit: mm

Part Number	CL No.	Number of Contacts	A	B	C	D	E	F	G
FX2-20P-0.635SH	572-2761-2	20	22.75	12.065	18.05	6.85	8.85	15.7	21.15
FX2A-20P-0.635SH	572-2771-6					—	—	—	
FX2-40P-0.635SH	572-2763-8	40	35.45	24.765	30.75	13.2	15.2	28.4	33.85
FX2A-40P-0.635SH	572-2773-1					—	—	—	
FX2-52P-0.635SH	572-2764-0	52	43.07	32.385	38.37	17.01	19.01	36.02	41.47
FX2A-52P-0.635SH	572-2774-4					—	—	—	
FX2-60P-0.635SH	572-2765-3	60	48.15	37.465	43.45	19.55	21.55	41.1	46.55
FX2A-60P-0.635SH	572-2775-7					—	—	—	
FX2-80P-0.635SH	572-2767-9	80	60.85	50.165	56.15	25.9	27.9	53.8	59.25
FX2A-80P-0.635SH	572-2777-2					—	—	—	

■Socket Type

●Lock Cable Type

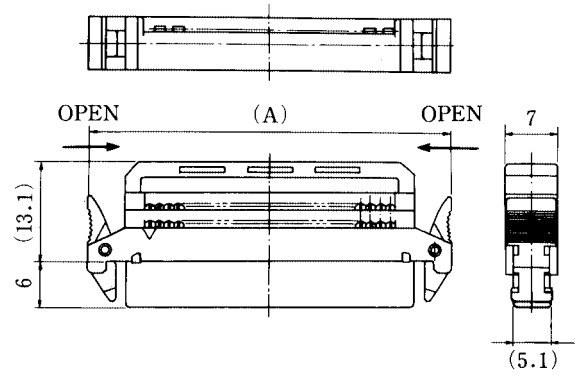
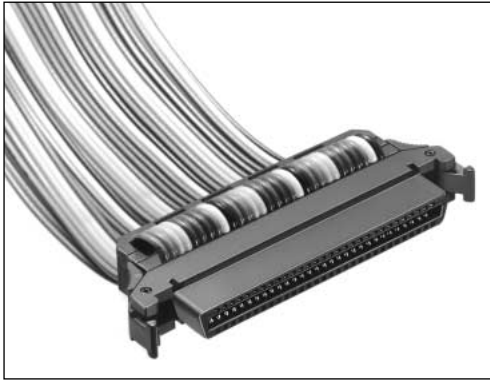

Combination View

Unit: mm

Part Number	CL No.	Number of Contacts	A
FX2B- 20SA-1.27R	572-0621-2	20	27.83
FX2B- 32SA-1.27R	572-0622-5	32	35.45
FX2B- 40SA-1.27R	572-0623-8	40	40.53
FX2B- 52SA-1.27R	572-0624-0	52	48.15
FX2B- 60SA-1.27R	572-0625-3	60	53.23
FX2B- 68SA-1.27R	572-0629-4	68	58.31
FX2B- 80SA-1.27R	572-0630-3	80	65.93
FX2B-100SA-1.27R	572-0628-1	100	78.63

●Unlock Cable Type

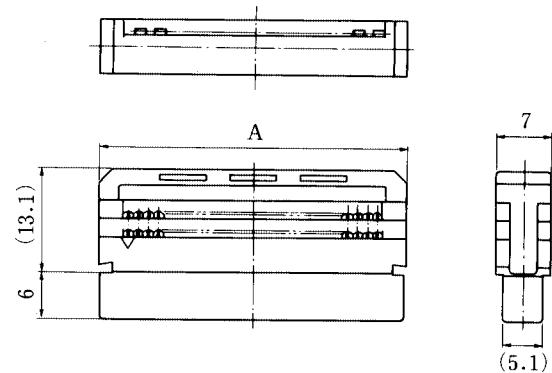
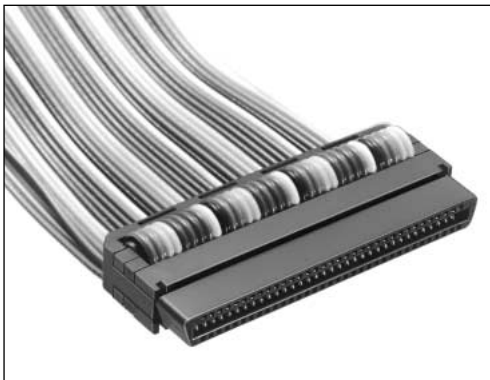

Combination View

Unit: mm

Part Number	CL No.	Number of Contacts	A
FX2BA- 20SA-1.27R	572-0671-0	20	18.05
FX2BA- 32SA-1.27R	572-0672-3	32	25.67
FX2BA- 40SA-1.27R	572-0673-6	40	30.75
FX2BA- 52SA-1.27R	572-0674-9	52	38.37
FX2BA- 60SA-1.27R	572-0675-1	60	43.45
FX2BA- 68SA-1.27R	572-0676-4	68	48.53
FX2BA- 80SA-1.27R	572-0677-7	80	56.15
FX2BA-100SA-1.27R	572-0678-0	100	68.85

◆Connection Tool

Type	Part Number	CL No.
Guide plate	FX2B(A)-GPA	550-0212-6
Connection press	Hi-Flex connection press	550-0082-2

Note:HRS6 cable cutter FC601 isn't required for FX2B(A) connection.
(Connected without convex-concave cutting.)

Header

Right Angle Type for Lock

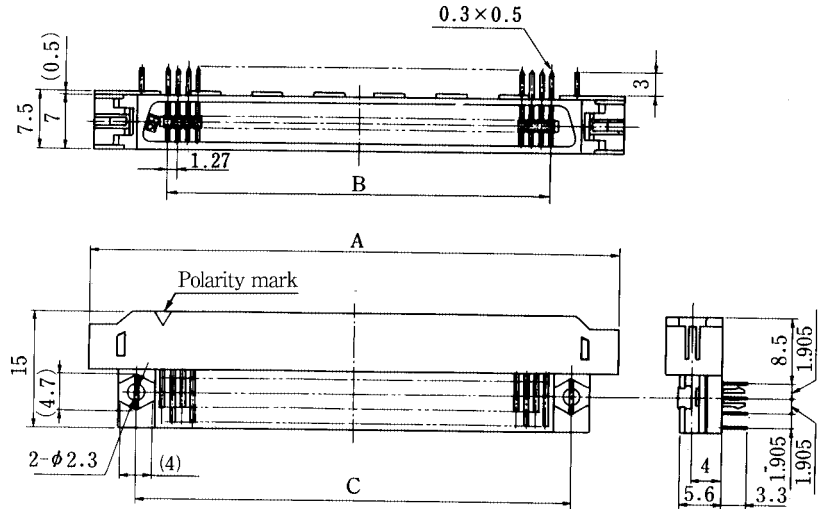

PCB mounting pattern

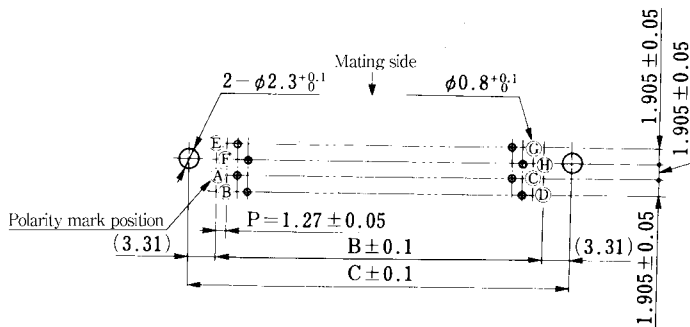

n= number of contacts

- Ⓐ a1 Ⓔ b1
- Ⓑ a2 Ⓕ b2
- Ⓒ $a\frac{n}{2}-1$ Ⓖ $b\frac{n}{2}-1$
- Ⓓ $a\frac{n}{2}$ Ⓗ $b\frac{n}{2}$

Unit: mm

Part Number	CL No.	Number of Contacts	A	B	C
FX2B- 20PA-1.27DS	572-0721-7	20	30.33	11.43	18.05
FX2B- 20PA-1.27DSL	572-0771-5				
FX2B- 32PA-1.27DS	572-0722-0	32	37.95	19.05	25.67
FX2B- 32PA-1.27DSL	572-0772-8				
FX2B- 40PA-1.27DS	572-0723-2	40	43.03	24.13	30.75
FX2B- 40PA-1.27DSL	572-0773-0				
FX2B- 52PA-1.27DS	572-0724-5	52	50.65	31.75	38.37
FX2B- 52PA-1.27DSL	572-0774-3				
FX2B- 60PA-1.27DS	572-0725-8	60	55.73	36.83	43.45
FX2B- 60PA-1.27DSL	572-0775-6				
FX2B- 68PA-1.27DS	572-0726-0	68	60.81	41.91	48.53
FX2B- 68PA-1.27DSL	572-0776-9				
FX2B- 80PA-1.27DS	572-0727-3	80	68.43	49.53	56.15
FX2B- 80PA-1.27DSL	572-0777-1				
FX2B-100PA-1.27DS	572-0728-6	100	81.13	62.23	68.85
FX2B-100PA-1.27DSL	572-0778-4				

Header No Cleaning Type

●Straight Type for Lock

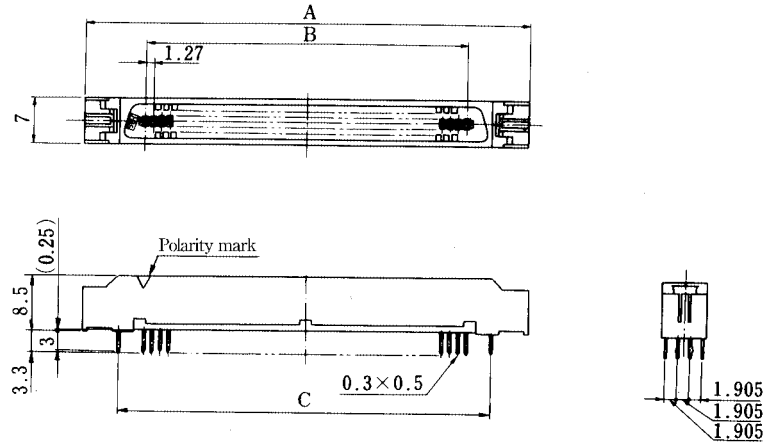

◆PCB mounting pattern

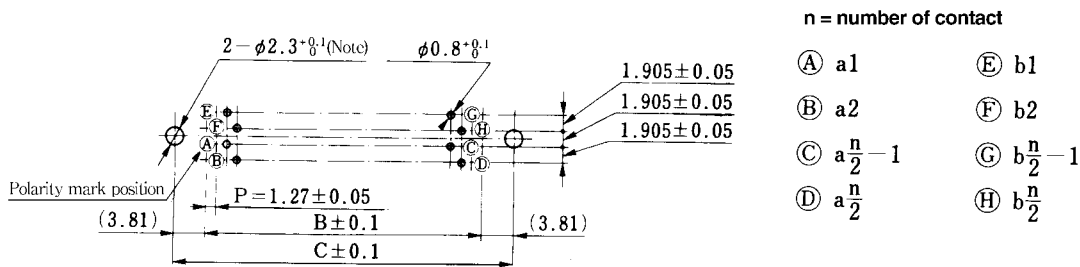

Note: Not required, unless the prefixed pin is attached.

Unit: mm

Part Number	CL No.	Number of Contacts	A	B	C
FX2B- 20PA-1.27DSA	572-0801-4	20	30.33	11.43	—
FX2B- 20PA-1.27DSAL	572-0851-2				19.05
FX2B- 32PA-1.27DSA	572-0802-7	32	37.95	19.05	—
FX2B- 32PA-1.27DSAL	572-0852-5				26.67
FX2B- 40PA-1.27DSA	572-0823-7	40	43.03	24.13	—
FX2B- 40PA-1.27DSAL	572-0873-5				31.75
FX2B- 52PA-1.27DSA	572-0824-0	52	50.65	31.75	—
FX2B- 52PA-1.27DSAL	572-0874-8				39.37
FX2B- 60PA-1.27DSA	572-0825-2	60	55.73	36.83	—
FX2B- 60PA-1.27DSAL	572-0875-0				44.45
FX2B- 68PA-1.27DSA	572-0826-5	68	60.81	41.91	—
FX2B- 68PA-1.27DSAL	572-0876-3				49.53
FX2B- 80PA-1.27DSA	572-0827-8	80	68.43	49.53	—
FX2B- 80PA-1.27DSAL	572-0877-6				57.15
FX2B-100PA-1.27DSA	572-0828-0	100	81.13	62.23	—
FX2B-100PA-1.27DSAL	572-0878-9				69.85

Header No Cleaning Type

●Straight Type for Lock

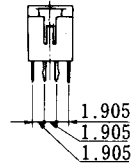
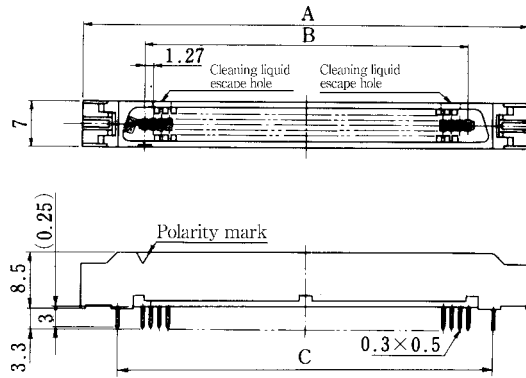

◆PCB mounting pattern

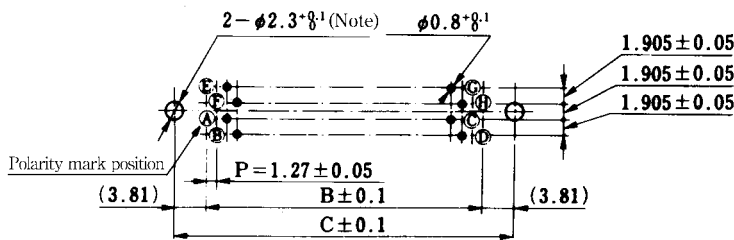

Note: Not required, unless the prefixed pin is attached

n= number of contacts

- Ⓐ a1 Ⓔ b1
- Ⓑ a2 Ⓕ b2
- Ⓒ $a \frac{n}{2} - 1$ Ⓖ $b \frac{n}{2} - 1$
- Ⓓ $a \frac{n}{2}$ Ⓖ $b \frac{n}{2}$

Unit: mm

Part Number	CL No.	Number of Contacts	A	B	C
FX2BA- 20PA-1.27DSA	572-0901-9	20	30.33	11.43	—
FX2BA- 20PA-1.27DSAL	572-0951-7				19.05
FX2BA- 32PA-1.27DSA	572-0902-1	32	37.95	19.05	—
FX2BA- 32PA-1.27DSAL	572-0952-0				26.67
FX2BA- 40PA-1.27DSA	572-0923-1	40	43.03	24.13	—
FX2BA- 40PA-1.27DSAL	572-0973-0				31.75
FX2BA- 52PA-1.27DSA	572-0924-4	52	50.65	31.75	—
FX2BA- 52PA-1.27DSAL	572-0974-2				39.37
FX2BA- 60PA-1.27DSA	572-0925-7	60	55.73	36.83	—
FX2BA- 60PA-1.27DSAL	572-0975-5				44.45
FX2BA- 68PA-1.27DSA	572-0926-0	68	60.81	41.91	—
FX2BA- 68PA-1.27DSAL	572-0976-8				49.53
FX2BA- 80PA-1.27DSA	572-0927-2	80	68.43	49.53	—
FX2BA- 80PA-1.27DSAL	572-0977-0				57.15
FX2BA-100PA-1.27DSA	572-0928-5	100	81.13	62.23	—
FX2BA-100PA-1.27DSAL	572-0978-3				69.85

Plug-in Connector for DISK Unit Connection

FX2M3 Series



■ Features

1. Plug-in Connector Equipped with Power contact

The total number of contacts contains 128 contacts, of which 120 contacts belong to the half pitch signal contacts, and the remained 8 contacts are used for the power contact. The power contact corresponds to the high current (7.5A).

2. Three-stage Sequential Structure

Considering the plug and play, 3 stages sequential structure is employed.

3. Flux Tight

The signal contact area of the straight dip type has completely prevented flux swell due to solder dipping.

4. Bus Line Connection

The socket side connector allow to connect the bus line.

5. Floating Mechanism

The socket type employs the floating (=1mm) mechanism for the panel installation.

Floating Mechanism

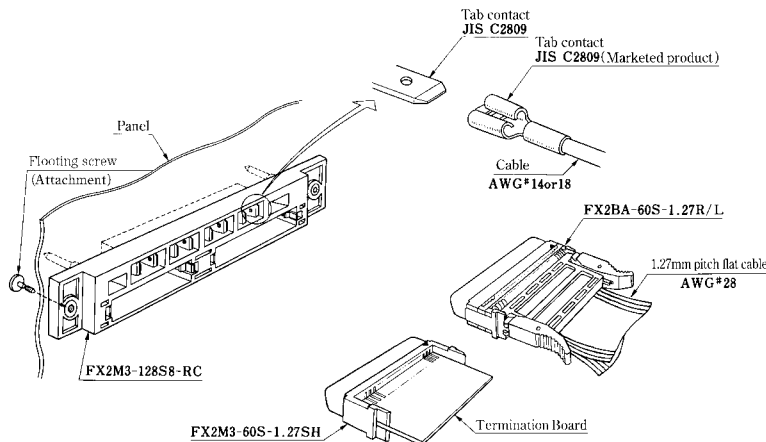

Bus Line Connection (Power Supply Side)

FX2M3-128S8-RC

Use Example

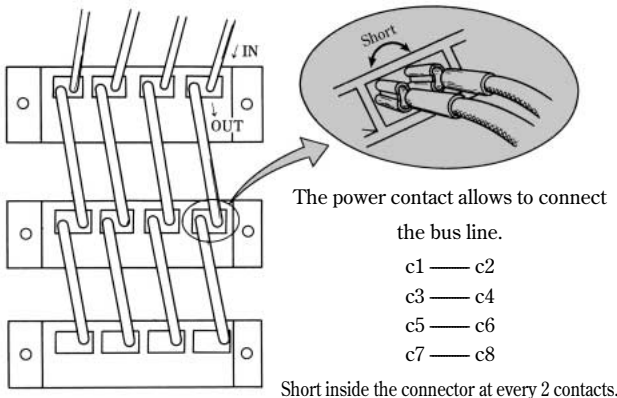

Bus Line Connection (For Signal)

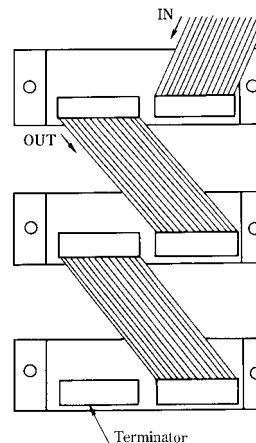

Since the signal contact can be engaged or disengaged, connection can be performed in combination with the cable type and the terminator as illustrated on the left.

■ Applications

Office computers and other information processing machines

■ Product Specifications

Rating	Current rating Signal contact: 0.5A Power contact: 7.5A	Voltage rating 125V AC	Operating Temperature Range: -55°C to +85°C Note 1. Operating Humidity Range : 40% to 80%	Storage Temperature Range: -10°C to +60°C Note 2. Storage Humidity Range: 40% to 70%
--------	---	---------------------------	--	---

Item	Specifications	Condition
1. Insulation Resistance	Signal contact 100M ohms min. Power contact 1000M ohms min.	250V DC
2. Withstanding voltage	No flashover or insulation breakdown.	Signal contact 300V AC for 1 minute Power contact 1000V AC for 1 minute
3. Contact Resistance	Signal contact 45m ohms max. Power contact 30m ohms max.	100mA
4. Vibration	No electrical discontinuity of 1μs or more	Frequency: 10 to 55 Hz, single amplitude of 0.75 mm, 2 hours in each of the 3 directions.
5. Humidity (Steady state)	Signal Contact Resistance: 55m ohms max. Insulation Resistance: 100M ohms min. Contact Contact Resistance: 30m ohms max. Insulation resistance: 1000M ohms min.	96 hours at temperature of 40°C and humidity of 90% to 95%
6. Temperature Cycle	Signal Contact Resistance: 55m ohms max. Insulation resistance: 100m ohms min. Contact Contact resistance: 30m ohms max. Insulation resistance: 1000m ohms min.	(-55°C: 30 minutes 15 to 35°C: 2 to 3 minutes 85°C: 30 minutes 15 to 35°C: 2 to 3minutes) 5 cycles
7. Operating Life	Signal contact Contact resistance: 55m ohms max. Power contact Contact resistance: 30m ohms max.	30 cycles
8. Resistance to Soldering heat	No deformation of components affecting performance.	Reflow: At the recommended temperature profile Manual soldering: 300°C for 10 seconds

Note 1: Includes temperature rise caused by current flow.

Note 2: The term "storage" refers to products stored for long period of time prior to mounting and use. Operating Temperature Range and Humidity range covers non conducting condition of installed connectors in storage, shipment or during transportation.

■ Material

Parts	Material	Finish	Remarks	
Insulator	Header	PBT/Polyamide	Black	UL94V-0
	Termination connector	PPS	Light brown	UL94V-0
Signal contact	Header	Brass	Selective gold plating	_____
	Receptacle, Termination connector	Phosphor bronze	Selective gold plating	
	Cable connector	Beryllium copper	Selective gold plating	
Power contact	Header	Brass	Tin plating	_____
	Receptacle	Phosphor bronze	Tin plating	
	Socket	Copper alloy	Tin plating	

■ Ordering Information

FX 2M3 - 128 S 8 - DSA L
 ① ② ③ ④ ⑤ ⑥

① Series name : FX2M3	⑤ Dip Contact style
② 128 : (Total Contact number)	DSA : Straight dip
③ Connector types : S : Receptacle or Socket P : Header	DS : Right angle dip
④ 8: Power contact number	RC : Socket (Note 1.)
	⑥ L: Board prefixed pin attached

● 60 Contacts Engage/Disengage Connector

FX 2BA - 60 S - 1.27 R/L
 ① ② ③ ④ ⑤ ⑥

① Series name : FX	④ Connector type : S. Socket (Cable connector) Receptacle (Termination connector)
② Series No. : 2BA..Cable connector 2M3..Termination connector	⑤ Contact pitch..1.27mm
③ Number of contacts : 60	⑥ R/L : ID connection type SH : Pinching SMT type

Part Number	CL No.	Number of Contacts		Remarks
		Signal	Power	
FX2M3-128S8-RC	572-1007-0	— (NOTE1)	8	Socket side
FX2M3-128P8-DSL	572-1008-2	60×2	8	Header side, Right angle dip
FX2M3-128S8-DSAL	572-1009-5	60×2	8	Receptacle side, Straight dip
FX2M3-128P8-DSAL	572-1010-4	60×2	8	Header side, Straight dip
FX2BA-60S-1.27R/L	572-1026-4	60 (NOTE2)	—	Cable connector
FX2M3-60S-1.27SH	572-1020-8	60 (NOTE2)	—	Termination connector

NOTE 1 : The signal connector is uninstalled. (Use FX2BA-60S-1.27R/L or FX2M3-60S-1.27SH..)

NOTE 2 : Installation to FX2M3-128S8-RC possible.

■Socket

FX2M3-128S8-RC
CL572-1007-0

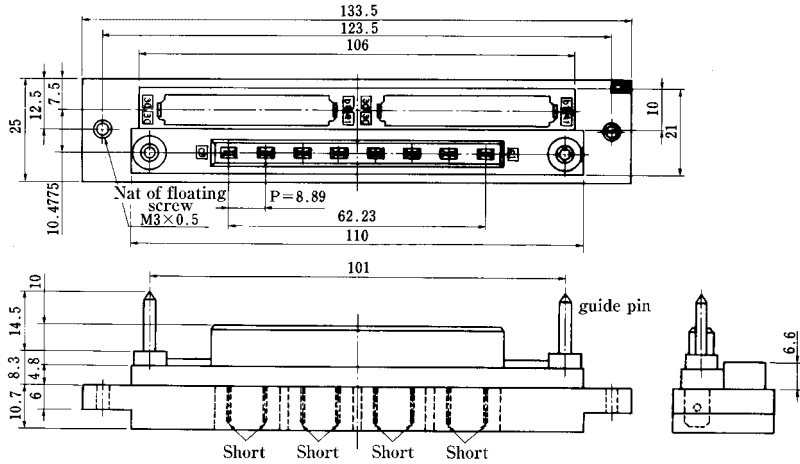

Floating screw
(Attachment)

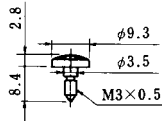

NOTE: The signal connector is uninstalled in this product.
Use FX2BA-60S-1.27R/L or FX2M3-60S-1.27SH.

◆Power contact Detailed View

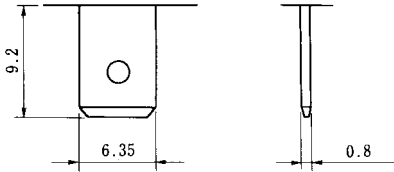

Please use the marketed tub Contact (product compliant to JIS standard: JIS2809) to connect the cable in the power contact area.

(However, use phosphor bronze as material.)

◆Combination View

(FX2BA-60S-1.27R/L or FX2M3-60S-1.27SH is installed in this product.)

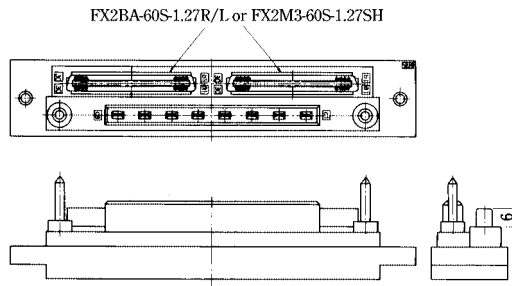

■ Cable Connector

FX2BA-60S-1.27R/L
CL572-1026-4

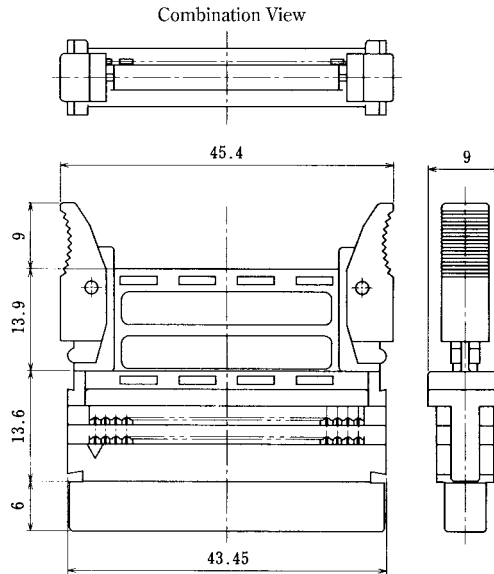

NOTE: This product can be installed in FX2M3-128S8-RC.
Applicable cable: 1.27 pitch flat cable
AWG28 (7/0.127) insulation covering diameter 0.9mm<UL2651>

◆ Cable Assembly View

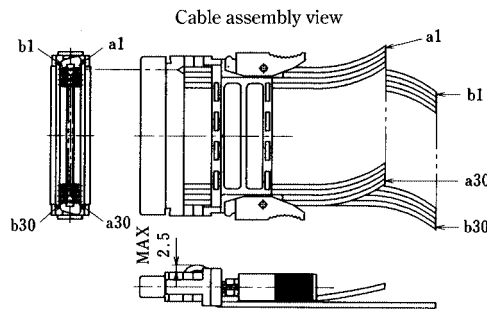

■ Termination Connector

FX2M3-60S-1.27SH
CL572-1020-8

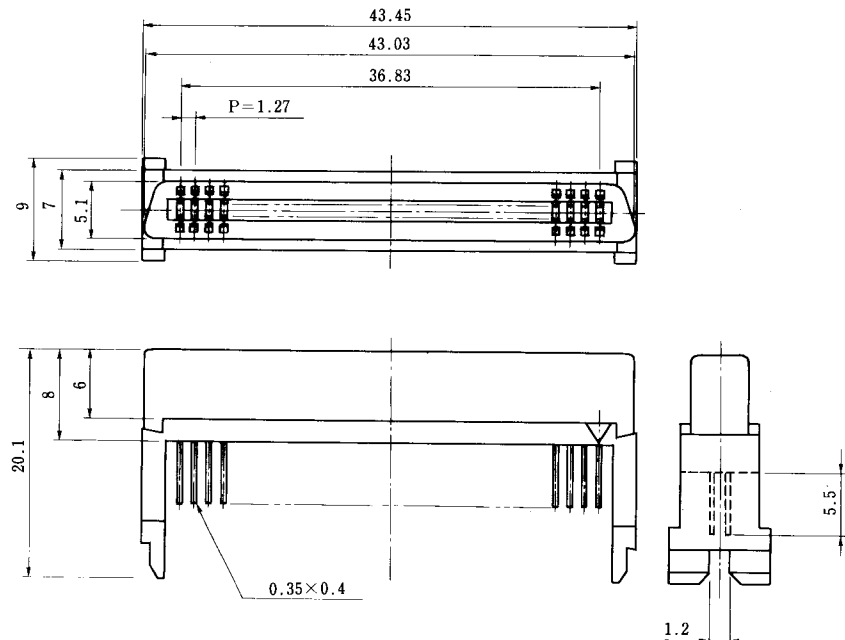

NOTE: The locking type is prepared for the termination connector.
Contact the HRS PCC Technical Department for details.

Header

●Right Angle Type

FX2M3-128P8-DSL
CL572-1008-2

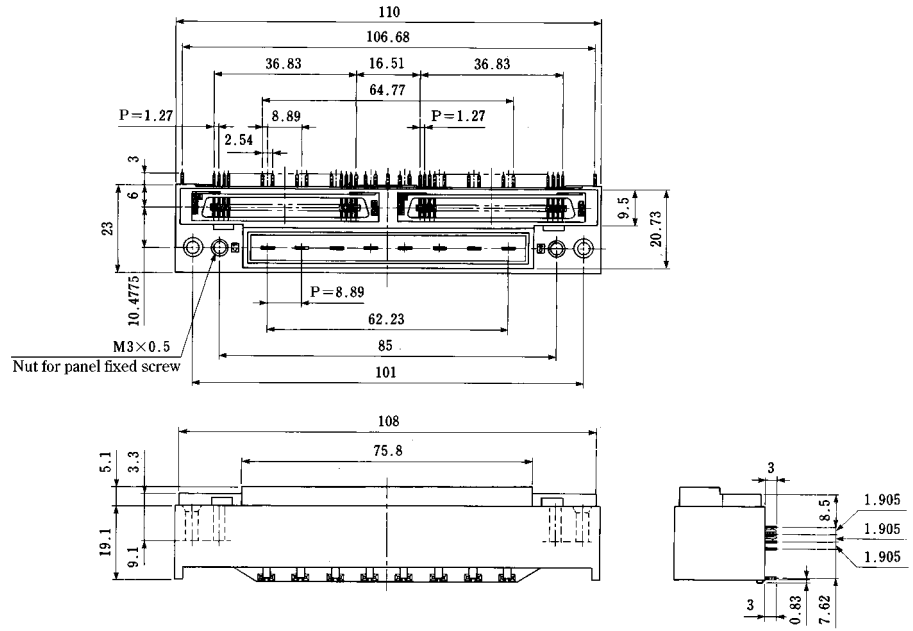

●Straight Type

FX2M3-128P8-DSAL
CL572-1010-4

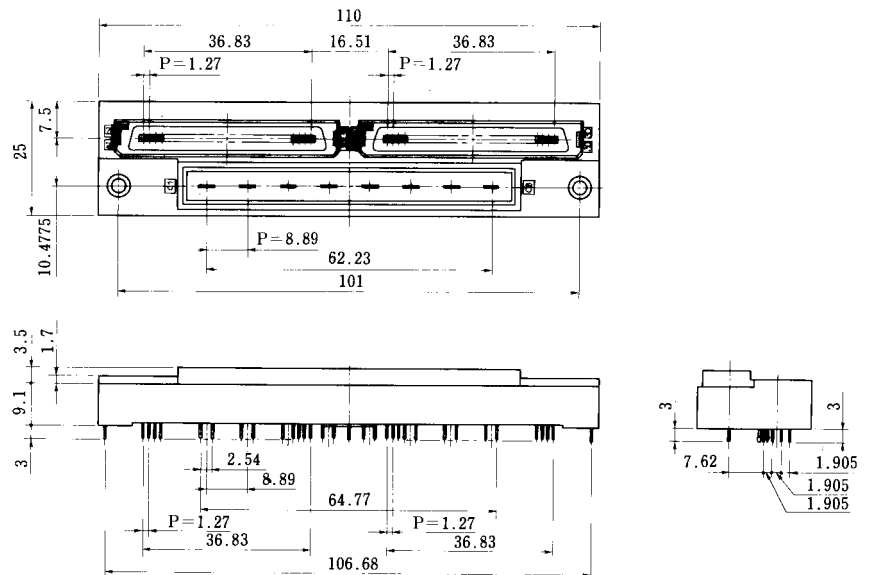

■ Receptacle

● Straight Type

FX2M3-128S8-DSAL
CL572-1009-5

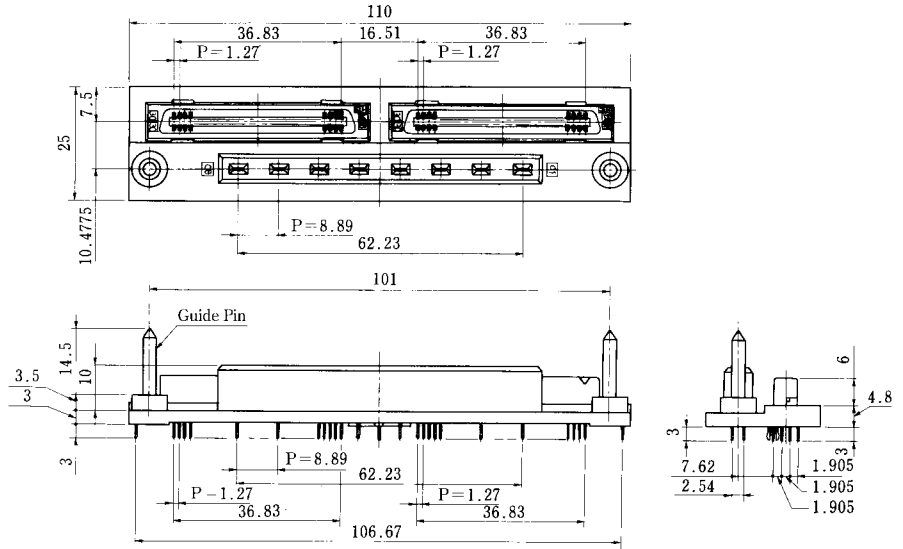

◆PCB mounting pattern

●FX2M3-128P8-DSL

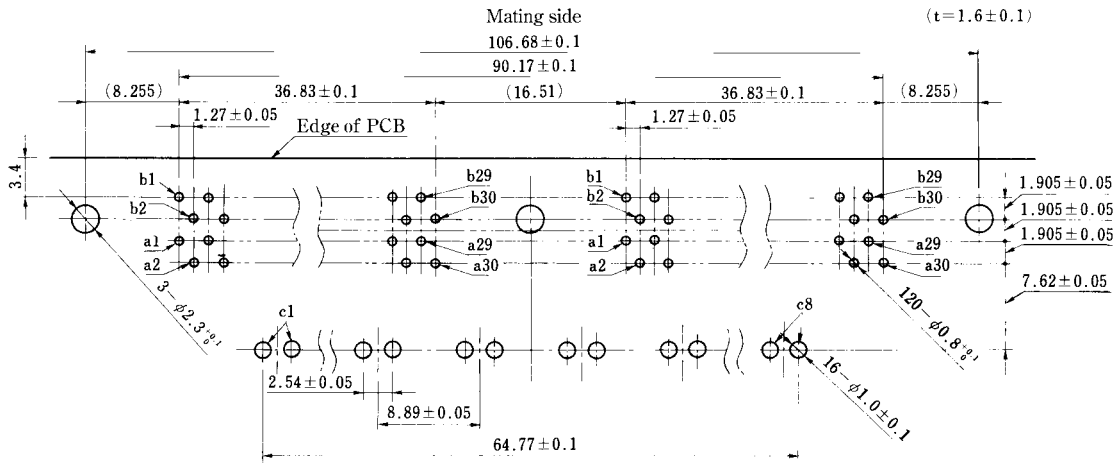

●FX2M3-128P8-DSAL

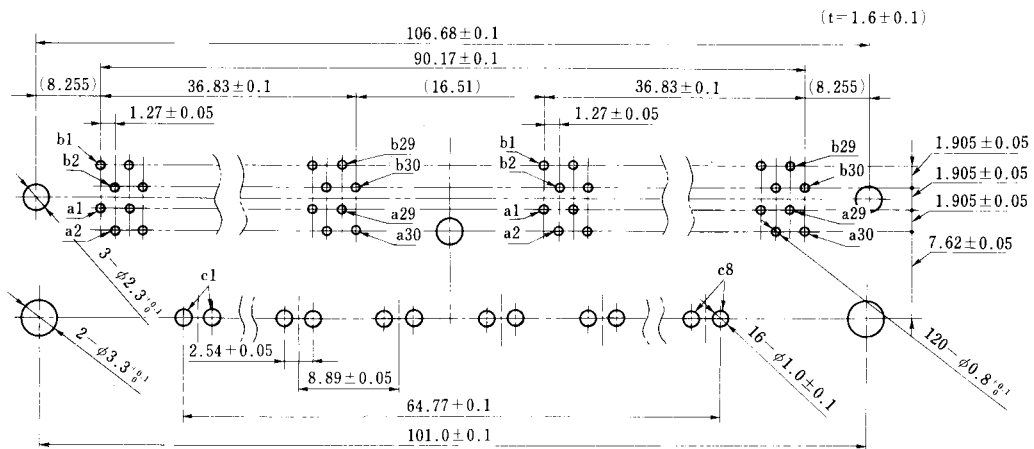

●FX2M3-128S8-DSAL

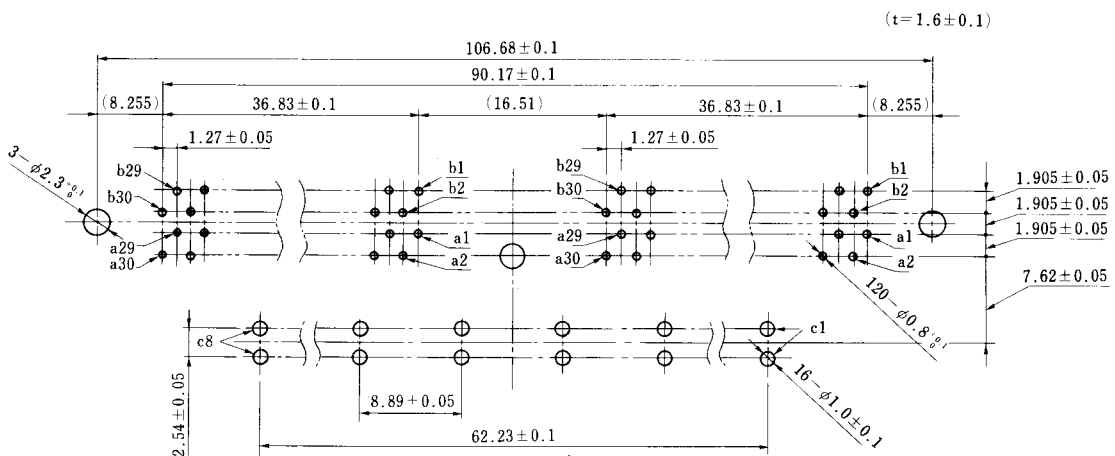

◆ Panel Cutouts (Mounted on Rear Side)

● FX2M3-128S8-RC

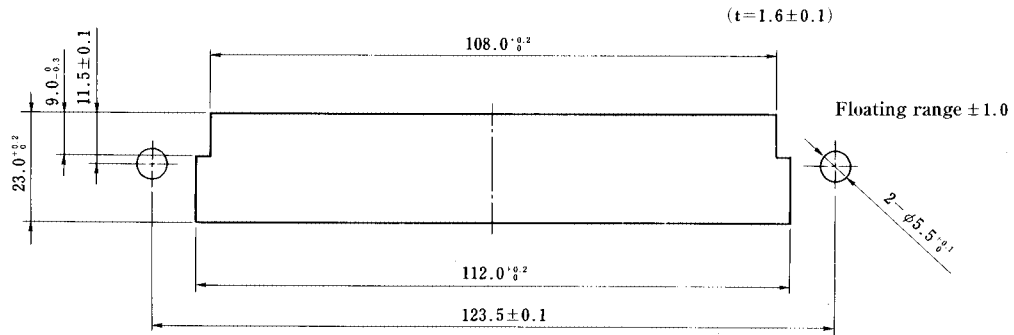

● FX2M3-128P8-DSL

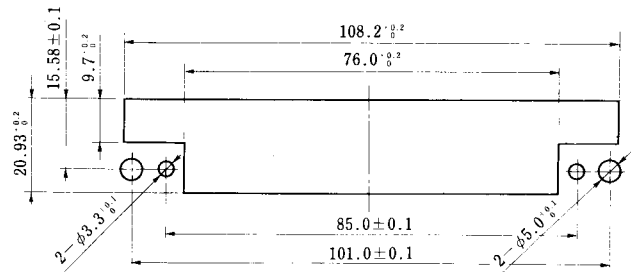

◆ FX2M3-60S-1.27SH PCB mounting pattern

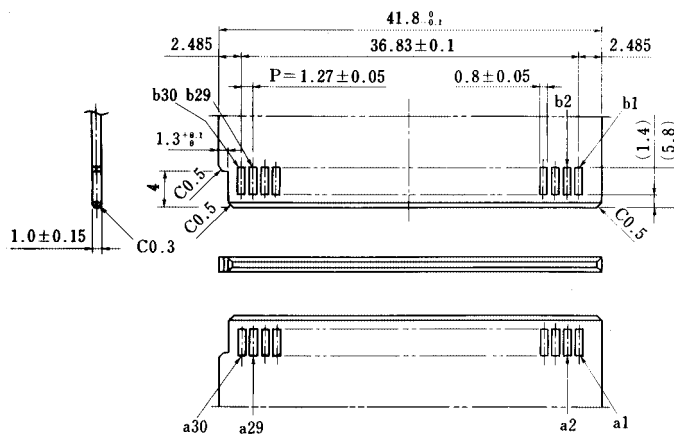

◆ Application Pattern

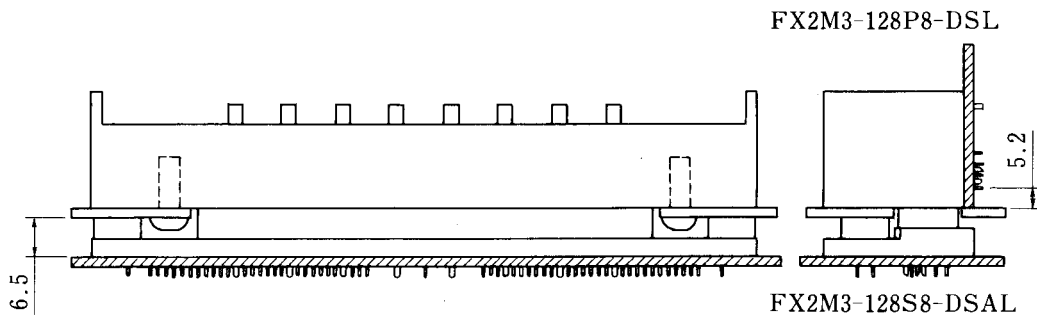
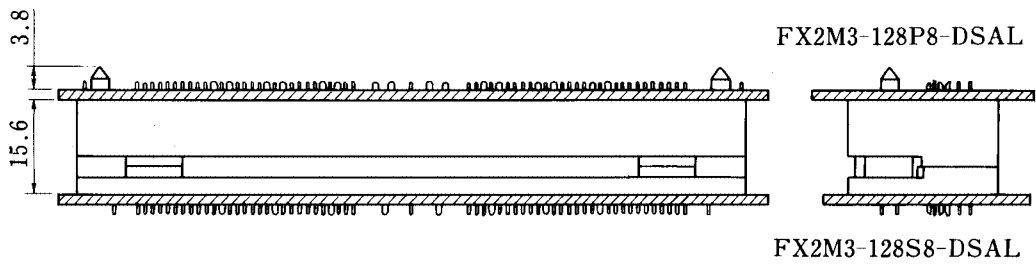
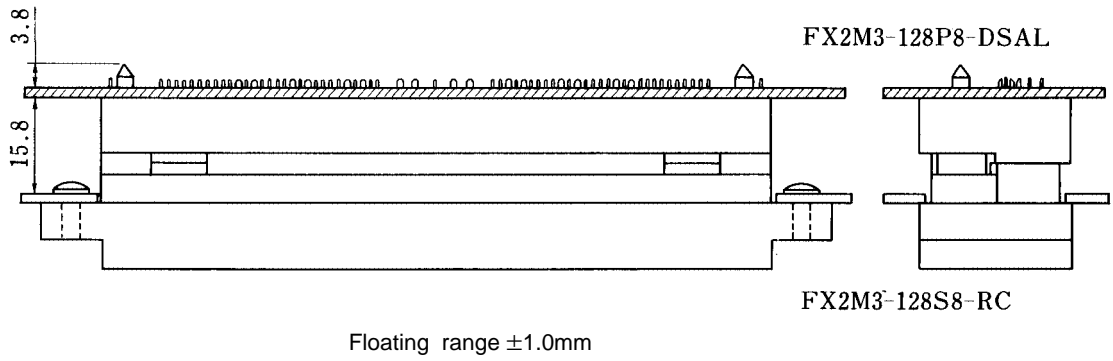
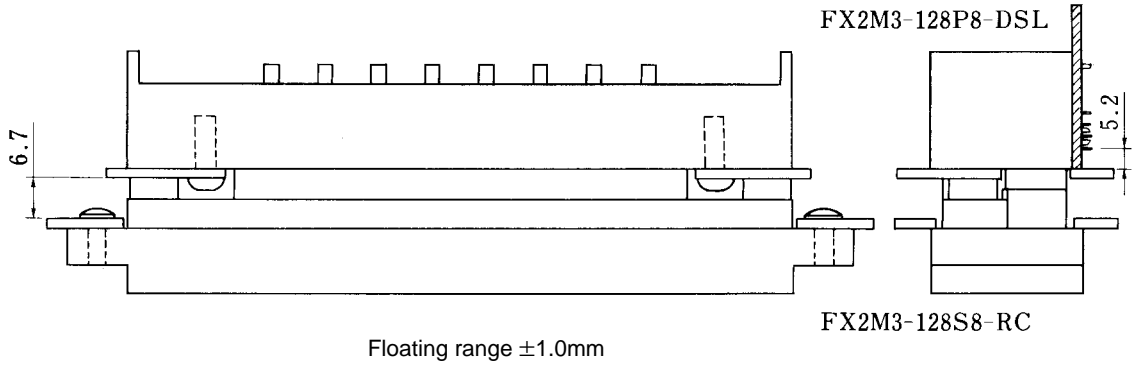

◆FX2M3-128S8-RC Operating Instructions

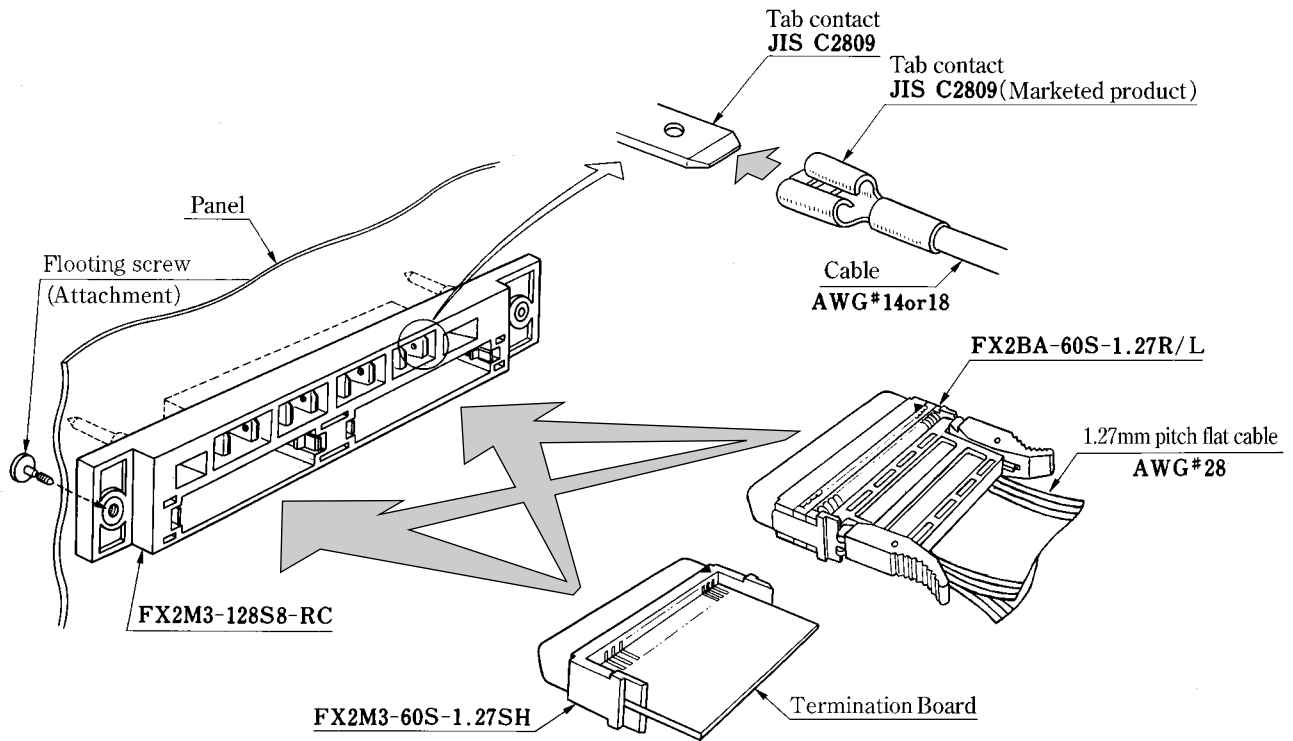

Power Side

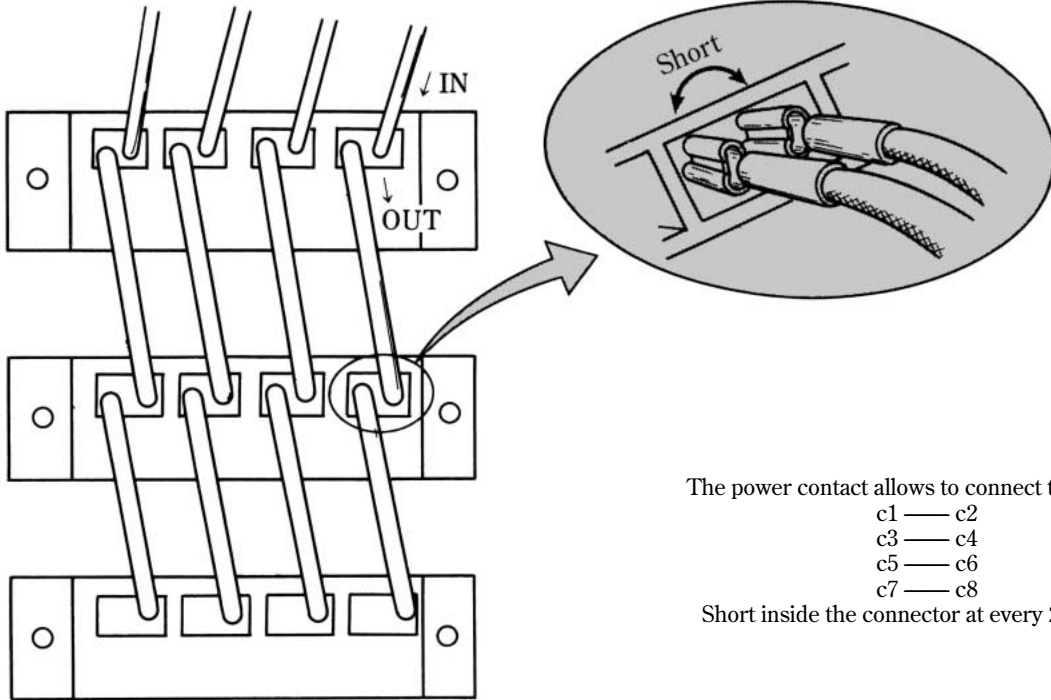

The power contact allows to connect the bus line.

- c1 — c2
- c3 — c4
- c5 — c6
- c7 — c8

Short inside the connector at every 2 contacts.

Signal Side

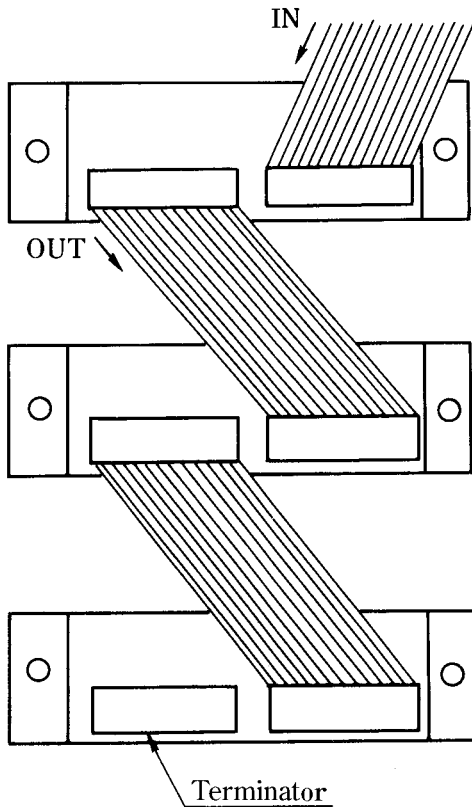

Since the signal contact can be engaged or disengaged, the contact can be used in combination with the cable type and the terminator as illustrated on the left.

FX2M6 Series

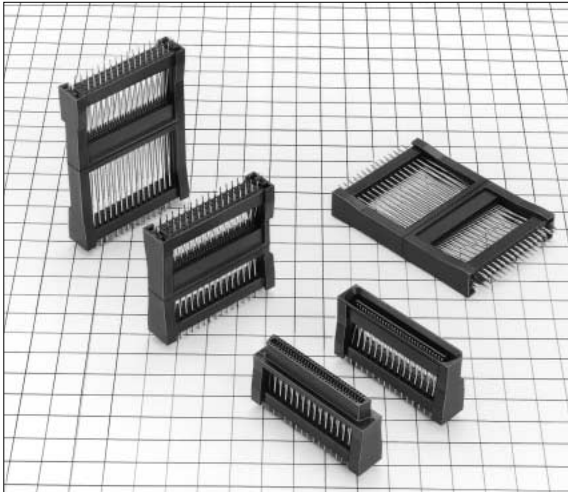

Ordering Information

FX2M6 **A** - **60** **P** - **1.27** **DSA** **L**
 ① ② ③ ④ ⑤ ⑥ ⑦

① Series Name	: FX2M6
② Type No.	: A
③ Number of contacts	: 60
④ Contact Style	
P	: Header
S	: Receptacle
⑤ Contact pitch	: 1.27mm
⑥ DSA	: Straight type
⑦ L	: Board prefixed pin

Stacking Variation

Unit: mm

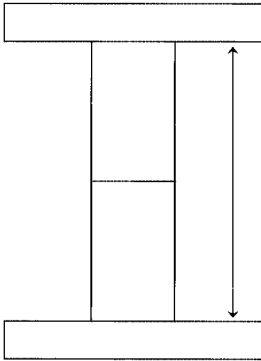

Header \ Receptacle	FX2C-60S -1.27DSA	FX2C2-60S -1.27DSA	FX2M6B-60S -1.27DSAL	FX2M6A-60S -1.27DSAL
FX2C-60P -1.27DSA	12	14	28.2	44.2
FX2C1-60P -1.27DSA	13	15	29.2 *2	45.2 *2
FX2C2-60P -1.27DSA	14	16	30.2 *2	46.2 *2
FX2M6B-60P -1.27DSAL	28.4 *1	30.4 *1	44	60
FX2M6A-60P -1.27DSAL	34.4 *1	36.4 *1	50	66

Note 1. Mate the male and female connectors to meet the allowable clearance within 1.0mm. However, set it within 0.4mm in combination *1.

Note 2. In case of combination *2, 0.6mm clearance occurs on the mating side, but no problem.

Note 3. After the board is mounted, fix the board by screws.

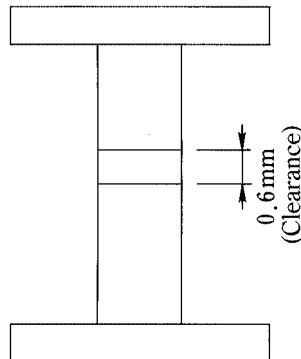

■Header

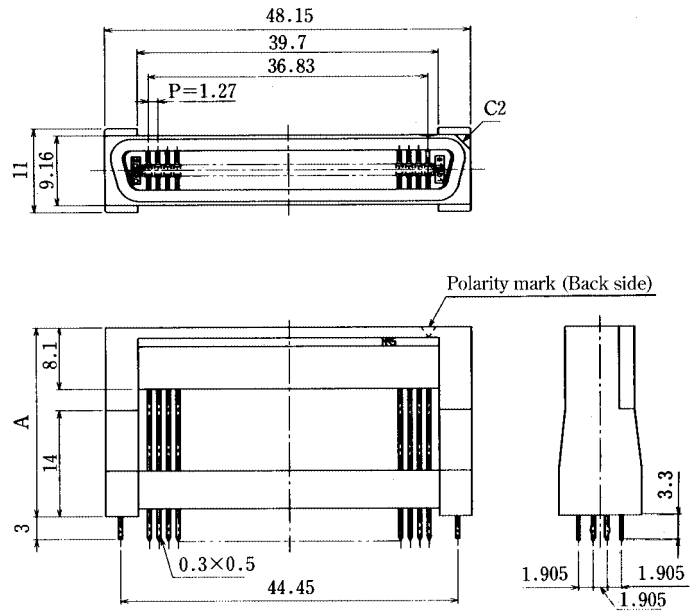
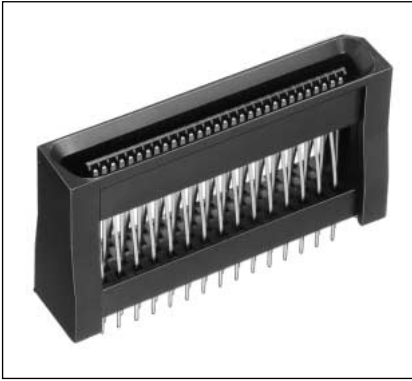

◆PCB mounting pattern

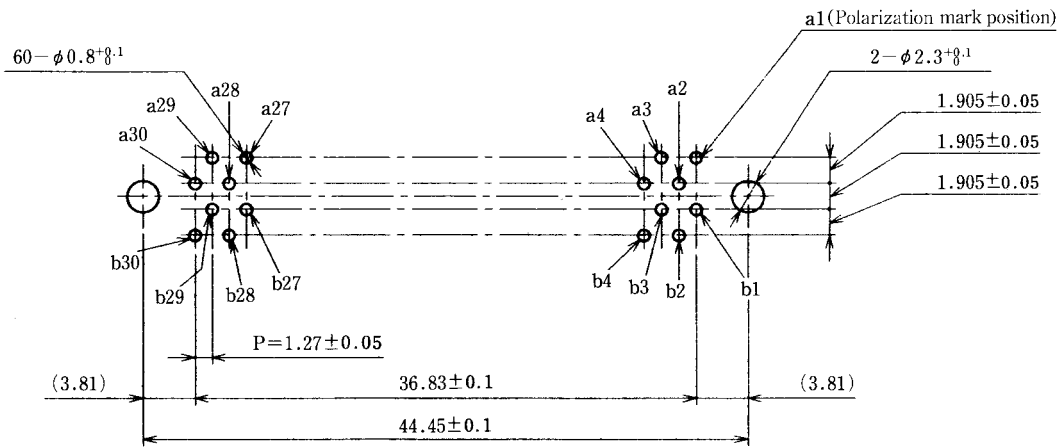

Applicable board thickness $t = 1.6$

Unit: mm

Part Number	CL No.	A
FX2M6A-60P-1.27DSAL	572-1036-8	30.9
FX2M6B-60P-1.27DSAL	572-1041-8	24.9

■ Receptacle

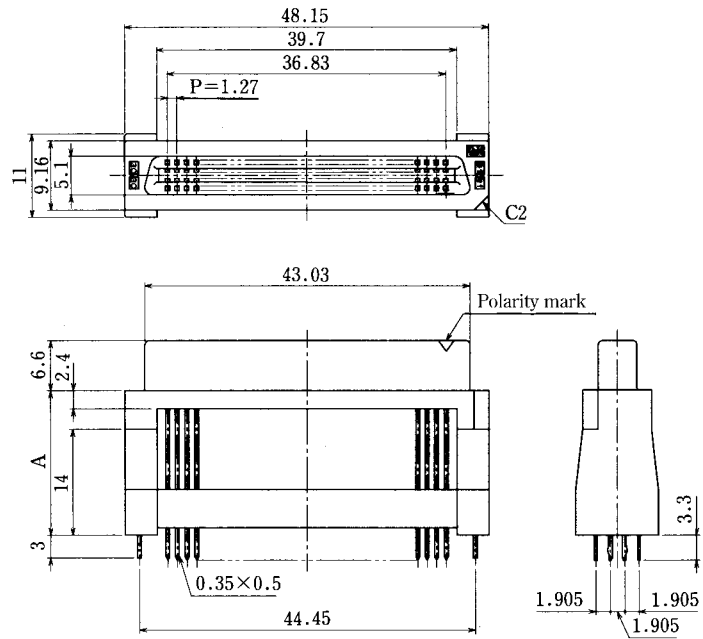
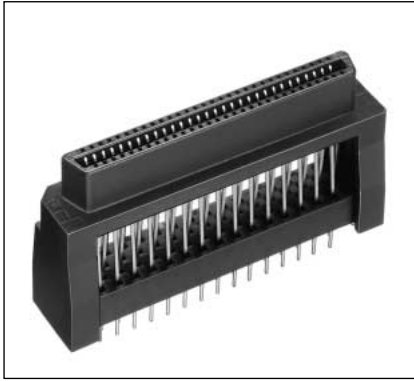

◆ PCB mounting pattern

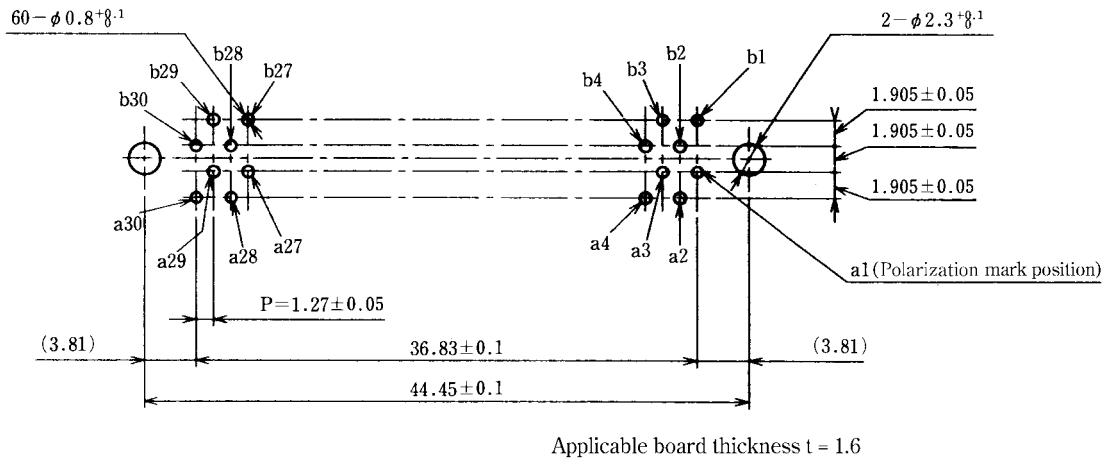

Unit: mm

Part Number	CL No.	A
FX2M6A-60S-1.27DSAL	572-1037-0	35.1
FX2M6B-60S-1.27DSAL	572-1042-0	19.1

◆ Connection Circuit Diagram

$$n = \frac{\text{Number of Contacts}}{2}$$

Type A, B

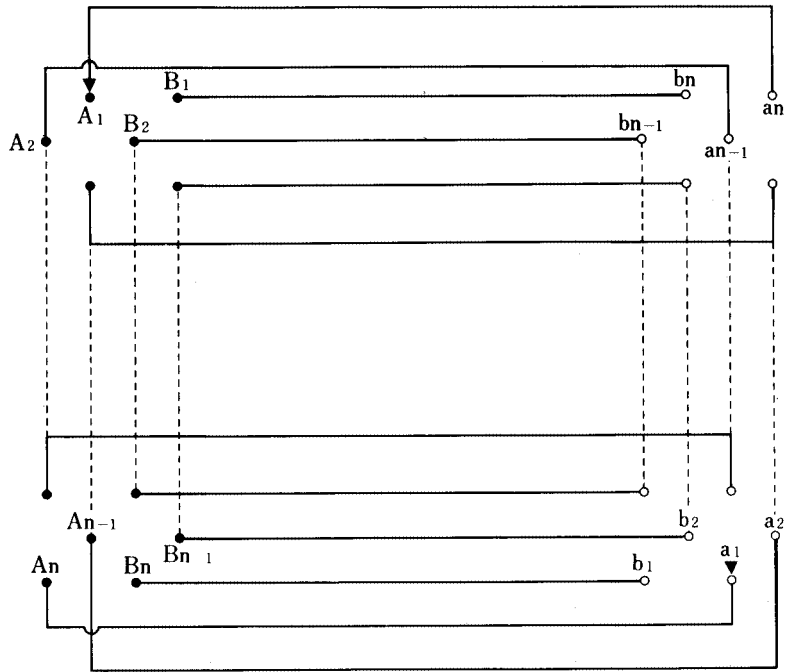
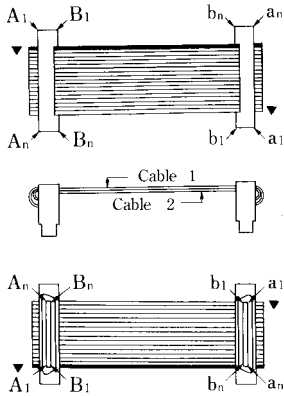

Connection to Cable 1

Connection to Cable 2

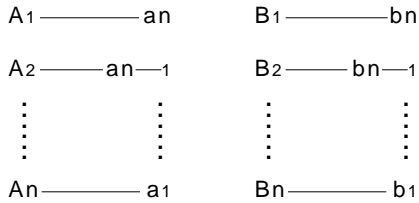

Type A, A

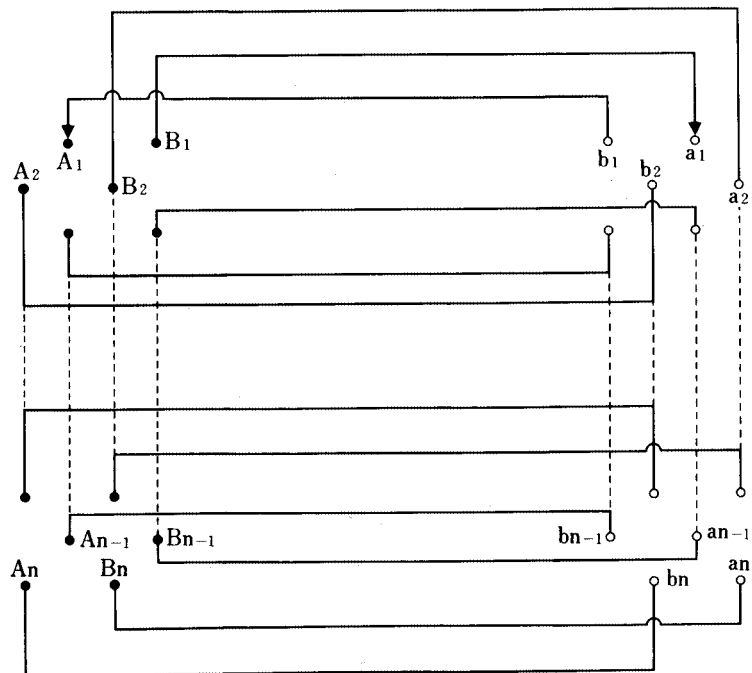
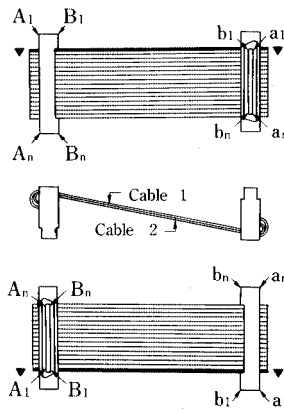

Connection to Cable 1

Connection to Cable 2

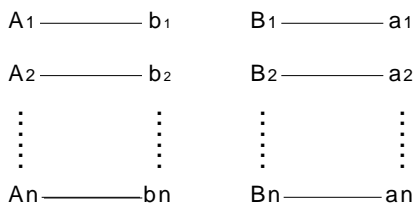

◆ Connector Use Hand book

1. Selecting connector

- ① The FX2 series is the perfect flux tight connector for the straight type in the soldering process, but it depends on the soldering process whether non-cleaning type (FX2C-*, FX2B-*) or cleaning type (FX2CA-*, FX2BA-*) should be selected. Please be sure to clean the right angle type (FX2-*, FX2B-*) connector. To clean the connector, please be sure to use detergent, containing no contaminant.
- ② To use the socket cable type, if a vibration or shock load is applied to the cable, select the lock type. In addition, if a load is applied to the cable, please be sure to use the cable clamp.

2. Prefixed Process to Board

If the prefixed process is required for mounting the board, please use the prefixed pin type. (Applicable board thickness $t = 1.6 \pm 0.1$)

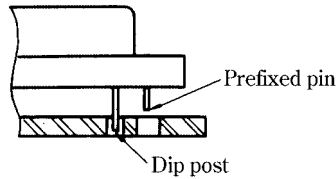

Note: In order to prevent the dip post breakage in the connector installation to the board, please insert the board in parallel to the connector so that the prefixed pin may be forcibly pushed in, after the dip post is guided to the board through-hole.

3. Mating Side Tolerance Clearance

(Example) FX2C-*P-1.27DSA and FX2C-*S-1.27DSA

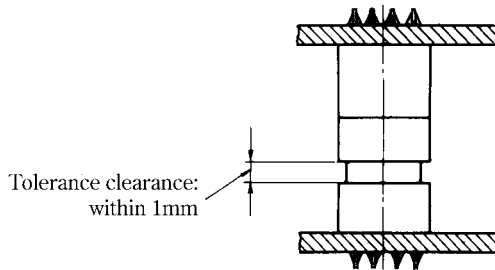

Set the tolerance clearance within 1mm to mate the male and female connectors. (Except for the lock cable type)

4. Cautions: for Using Lock Cable Type

- ① When the connector is mated, insert the connector by the end so as not to make a clearance.
- ② When the connector is inserted or extracted, please insert or extract the connector after the both lock levers are laid inside. If the connector is inserted or extracted with either lock lever laid, the connector may be broken.
- ③ please do not open the lock lever outside.

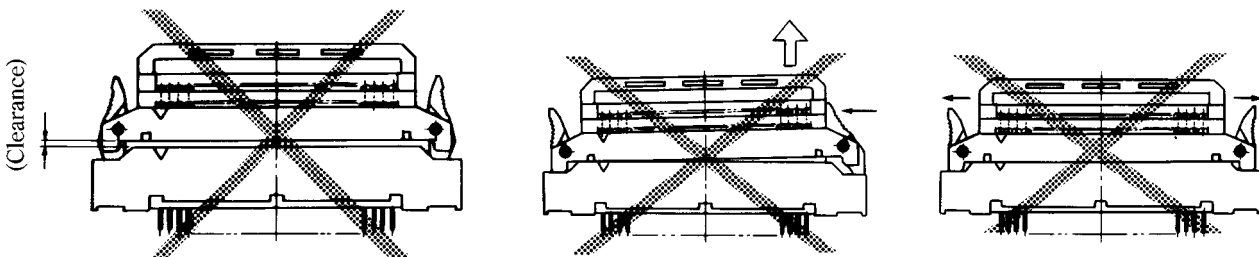

5. SMT Type Connector Mounting Temperature Profile (Reference)

● IR Reflow

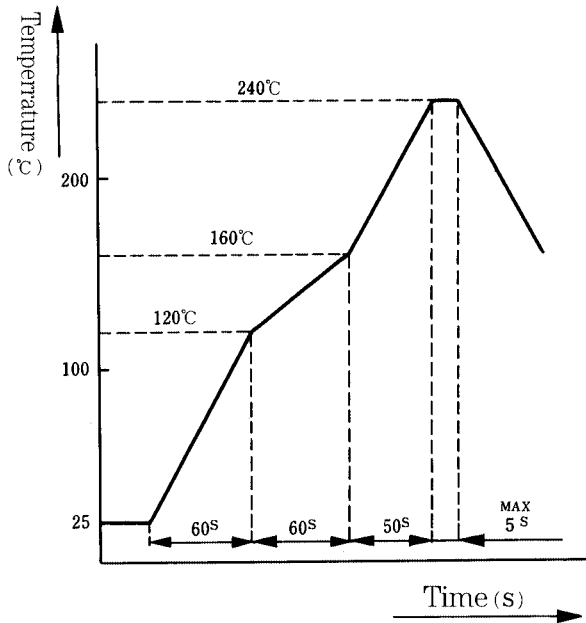

Applicable Conditions

Reflow system

:IR reflow

Solder

: Paste type 63 Sn/37 Pb
(Flux content 11 wt%)

Test board

: Glass epoxy 110mm x 40mm x 1.6 mm

Metal mask thickness

: 0.2 mm (Straight type)
0.15mm (Right angle type)

Recommended temperature profile.

The temperature may be slightly changed according to the solder paste type and amount.

6. SMT Type Connector mated height

As shown in the application pattern, the mated height of the male/female connector doesn't contain the solder paste thickness. Thus, after the connector installation in the board, consider that the mated height will be widened in proportion to the solder paste thickness.